

Installation, Operation & Maintenance Manual

PT-Series Petroleum Pumps

For Refined Petroleum Products and Industrial Solvents



Model PT20

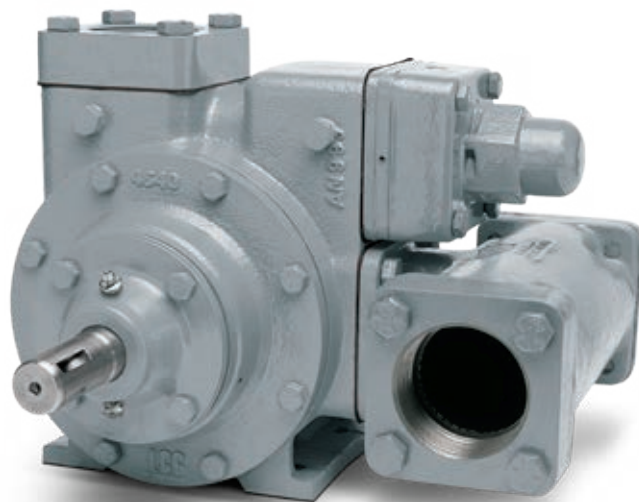

Model PT25 with optional air operated valve (AOV) and strainer



Model PT30

Warning: (1) Periodic inspection and maintenance of Corken products is essential. (2) Inspection, maintenance and installation of Corken products must be made only by experienced, trained and qualified personnel. (3) Maintenance, use and installation of Corken products must comply with Corken instructions, applicable laws and safety standards (such as NFPA Pamphlet 58 for LP-Gas and ANSI K61.1-1972 for Anhydrous Ammonia). (4) Transfer of toxic, dangerous, flammable or explosive substances using Corken products is at user's risk and equipment should be operated only by qualified personnel according to applicable laws and safety standards.

Solutions beyond products...

CORKEN[®]

Warning

Install, use, and maintain this equipment according to Corken's instructions and all applicable federal, state, local laws, and codes. Periodic inspection and maintenance is essential.

Corken One Year Limited Warranty

Corken warrants that its products will be free from defects in material and workmanship for a period of one year from date of installation, provided that the warranty shall not extend beyond twenty-four (24) months from the date of shipment from Corken. If a warranty dispute occurs, the distributor may be required to provide Corken with proof of date of sale. The minimum requirement would be a copy of the distributor's invoice to the customer. Corken products which fail within the warranty period due to defects in material or workmanship will be repaired or replaced at Corken's option, when returned, freight prepaid to Corken, Inc., 9201 North I-35 Service Road, Oklahoma City, OK. 73131.

Parts subject to wear or abuse, such as mechanical seals, vanes, piston rings, packing and other parts showing signs of abuse are not covered by this limited warranty. Also, equipment, parts and accessories not manufactured by Corken but furnished with Corken products are not covered by this limited warranty and purchaser must look to the original manufacturer's warranty, if any. This limited warranty is void if the Corken product has been altered or repaired without the consent of Corken.

All implied warranties, including any implied warranty of merchantability or fitness for a particular purpose, are expressly negated to the extent permitted by law and shall in no event extend beyond the expressed warranty period.

Corken disclaims any liability for consequential damages due to breach of any written or implied warranty on Corken products. Transfer of toxic, dangerous, flammable or explosive substances using Corken products is at the user's risk. Such substances should be handled by experienced, trained personnel in compliance with governmental and industrial safety standards.

Important notes relating to the European Union (EU) Machinery Directive

Pumps delivered without electric motors are not considered as machines in the EU Machinery Directive. These pumps will be delivered with a Declaration of Incorporation. The fabricator of the machinery must assure and declare full compliance with this Directive before the machine in which the pump will be incorporated, or of which it is a part, is put into service.

Contacting the Factory

Before contacting the factory, note the model and serial numbers. The serial number directs Corken personnel to a file containing all information on material specifications and test data applying to the product. When ordering parts, the Corken service manual or Installation, Operations, and Maintenance (IOM) manual should be consulted for the proper part numbers. **ALWAYS INCLUDE THE MODEL NUMBER AND SERIAL NUMBER WHEN ORDERING PARTS.**

The model and serial numbers are shown on the nameplate of the unit. Record this information for future reference.

Model No. _____

Serial No. _____

Date Purchased _____

Date Installed _____

Purchased From _____

Installed By _____

Table of Contents

Principles of the PT-Series Pumps	4
Exclusive Features of the PT-Series Pumps	4
Chapter 1—Installation (Truck)	5
1.1 Power Take-Off Drive Systems	5
1.2 Hydraulic Drive Installation	6
1.3 Pump Rotation	6
Chapter 2—Operation (Truck)	6
Chapter 3—Installation (Stationary)	7
3.1 Coupling alignment	7
3.2 Driver Installation	8
Chapter 4—Operation (Stationary)	9
Chapter 5—Maintenance of the Pump System	9
5.1 Pump Maintenance Schedule	10
5.2 Bearing Lubrication	10
5.4 Strainers	10
5.5 Disassembly Instructions	10
5.6 Assembly Instructions	11
5.7 Vane Replacement	12
5.8 Bypass Valve Assembly	13
5.9 Air Operated Valve (AOV) Assembly	13
Chapter 6—Repair Kits	14
Appendices	
A. Model Number Identification Code and Available Options	15
B. Specifications	16
C. Performance	17
D. Outline Dimensions	19
E. Parts Details	26
F. Troubleshooting Guide	36
G. Extended Storage	37

Principles of the PT-Series Pumps

The PT-Series pumps are a special type of rotary positive displacement pump, known as a sliding vane pump.

The sliding vane pump has many of the positive displacement advantages of the gear pump, plus the ability to compensate for wear, and operate at a lower noise level.

The sliding vane pump consists of a rotor turning inside a cam that is machined eccentrically in relation to the rotor. As the rotor turns, the liquid that is trapped between the rotor, cam and vanes is displaced. The PT-Series pumps are made with vanes produced from advanced polymers which exhibit extremely low coefficients of friction. The self adjusting vanes compensate for wear and help extend the life of the pump.

Exclusive Features of the PT-Series Pumps

Pumping liquids from a delivery truck can be difficult, so more attention must be given to the design and manufacturing of the pump and to its installation and operation.

In addition to being well suited for handling petroleum products, PT-Series pumps have a number of other features that make it easy to operate and maintain.

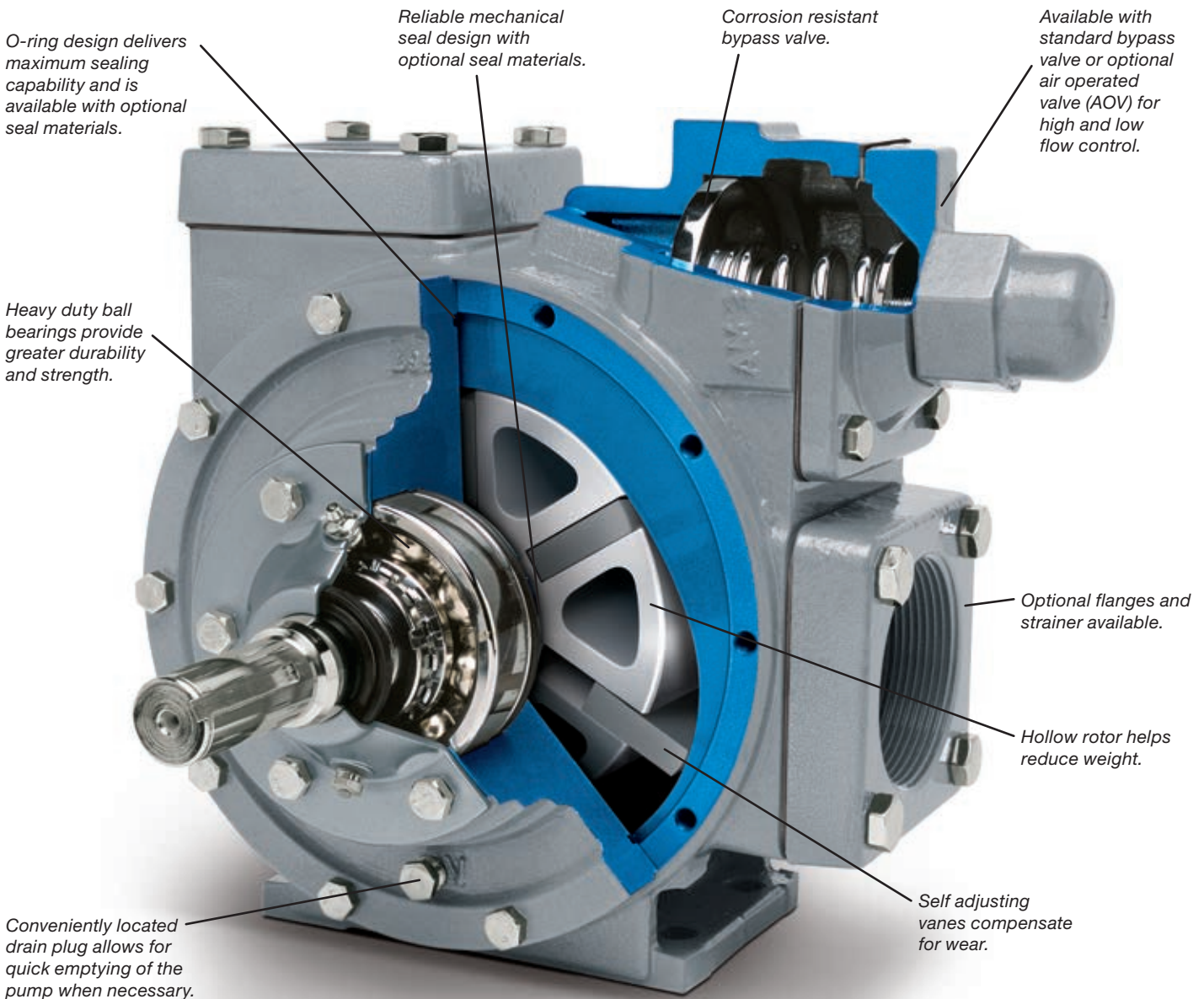

Chapter 1—Installation (Truck)

The mechanical installation of the PT-Series pump is a simple matter. A rotation arrow is located on the side of the pump. Examine the PTO and determine the direction of its rotation before installing the pump. The PT-Series pump will match either PTO rotation. Connect the drive shaft to the pump shaft that turns the pump in the direction of the arrow.

The PTO SELECTION is important. For maximum performance, the pump requires a PTO with an average output speed of 500 to 700 RPM. In addition, the truck engine must be operating at the appropriate RPM to maintain oil pressure, water circulation, and the electrical system.

THE DRIVESHAFT that connects the pump to the PTO should be of the “splined” or slip type. This type of driveshaft permits the shaft to adjust for PTO movement and twisting of the truck frame. A fixed driveshaft will transfer the forces directly to the pump and PTO and shorten the life of both considerably. The yokes of the driveshaft universal joints must be positioned as shown in Figure 1. Improper positioning will cause premature wear and potentially destroy the bearings in the pump and PTO.

INLET PIPING should be as short as possible and at least the minimum diameter specified for the model with few restrictions so that the pressure drop is limited.

The outlet piping should include the following:

1. A pressure gauge should be installed in the pump outlet or near it. A pressure gauge is necessary to determine the efficiency of the pumping system.
2. If a meter with an air eliminator is installed, never pipe the eliminator directly into the pump inlet piping or into the liquid part of the system at any point (refer to the meter installation manual).
3. The discharge piping should be at least the same size as the meter piping.

1.1 Power Take-Off Drive Systems

Proper pump operation and long life is directly dependent upon a good drive system. Many truck pumps utilize a power train consisting of shafts and universal joints located between the power take-off shaft of the truck engine and the pump.

There are several basic principles that should be followed in designing a PTO drive. To produce a workable power train that results in long pump life and reduced drive wear, these principles should not be violated.

First, the driver shaft and the driven shaft must be parallel to one another within plus or minus one degree. Improper alignment will cause jerking and back and forth “whip” to the pump shaft; thereby imparting a surging pulsation to the liquid flow which results in noise, vibration and abnormal wear.

Second, the angle of the “floating” shaft should be within the limits for the particular equipment being used (usually a maximum of 15° at pump speeds up to 800 RPM). To ensure that shaft expansion or contraction does not distort the drive system, a splined slip joint should be placed between the two universal joints. Again, the drive shaft should be of the “splined” or slip type to permit the shaft to adjust for PTO movement and twisting of the truck frame. A fixed drive shaft transmits the forces directly to the pump and PTO which will shorten the life of both considerably.

Third, the yokes of the drive shaft universal joints must be in a parallel position. Figure 1 below illustrates the proper arrangement of the yokes.

Improperly installed U-joints will cause premature failure of U-joints as well as bearings in the pump and PTO. Properly mounted, the second universal gives uniform motion to the drive shaft by compensating for the rotational error introduced by the first U-joint. An even number of universal joints (2, 4, 6 etc.) should always be used. An odd number of U-joints will cause unbalanced pump shaft rotation. This problem becomes greater with increased angularity.

Other points to consider include the proper sizing of the shaft components with a maximum horsepower load to be expected, good alignment of hanger bearings and proper pump coupling alignment.

Improper PTO systems account for a high percentage of truck pump failures. Always remember to disengage the clutch before shifting the PTO into gear. Shifting the PTO into gear without disengaging the clutch imparts an enormous shock on the PTO, drive shaft, pump and meter and will soon damage one or all of them.

For proper installation of pump drives, follow the rules listed below:

1. Driver shaft and pump shaft must be parallel, plus or minus one degree.
2. Operating angle of the “floating” shaft must be 15° maximum.
3. Universal yokes must be in line and parallel.
4. Splined slip joints must be used where needed.
5. Use an even number of universal joints.

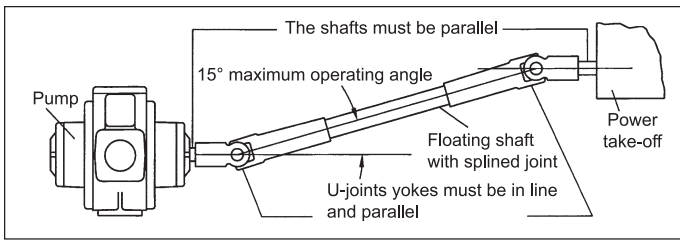



Figure 1: Shaft alignment

 Note: A drive shaft guard between the pump and PTO should be installed (not shown).

6. Always use the least practical number of shafts.

PTO selection and drive system design is extremely important. The PTO should have an average output speed up to 640 RPM to maximize the performance of the PT-Series pump when the truck engine is operating at the recommended speed.

The designer of the drive system must select a PTO drive shaft capable of meeting the torque requirements of the pumping system.

1.2 Hydraulic Drive Installation

Hydraulic motors must be well supported and keep their shafts parallel to the pump shaft. To drive the PT-Series pumps hydraulically, Corken provides a close-coupled hydraulic motor adapter. The adapter aligns the hydraulic motor drive and the pump shaft via a locking and a flexible coupling connected to a keyed shaft. This adapter must be lubricated with grease at least every three months. Refer to the “Bearing Lubrication” section of this manual for instructions.

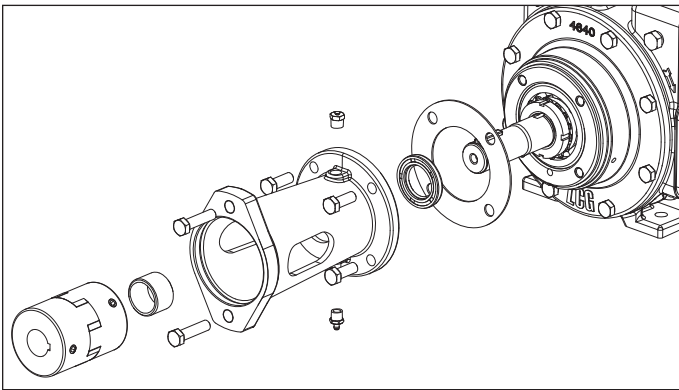

Figure 2: Hydraulic Drive (see Appendix E for Part Details)

1.3 Pump Rotation

For proper pump rotation, make sure the pump’s rotation arrows match the pump driver rotation (see Appendix E for parts details).

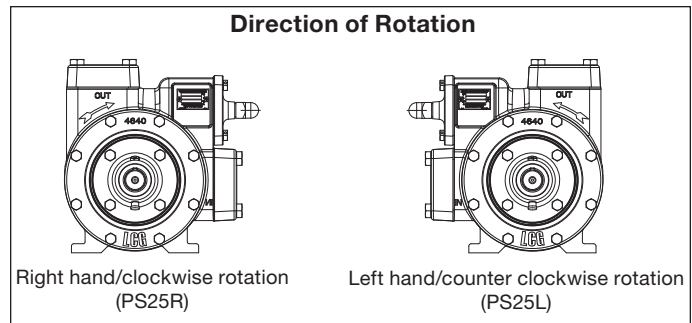

Figure 3: Direction of Rotation

Chapter 2–Operation (Truck)

The following steps should be performed for the initial pumping operation:

1. Close the shutoff valve on the end of the delivery hose.
2. Start the pump and cycle the nozzle open and closed to clear all air from the system.
3. Check the discharge pressure on the outlet of the pump. This pressure is typically set at 80 to 95 psi.

4. Bypass Valve Adjustment

For a standard bypass valve, locate the adjustment set screw under the bypass valve cap (see Appendix E for parts details). Turn adjustment screw clockwise to increase pressure and flow. Turn counter clockwise to decrease pressure and flow.

Close the nozzle and check the bypass pressure. If too high, turn adjustment screw counter clockwise until desired pressure is reached.

With the hose nozzle open, adjust the pump bypass valve setting to the desired flow rate. Close the nozzle slowly and check the system pressure. **CAUTION: DO NOT EXCEED A CLOSED NOZZLE PRESSURE OF 125 PSI.**

Replace bypass valve cap and bypass valve cap gasket with seal washer and tighten.

5. Air Operated Valve (AOV) Adjustment

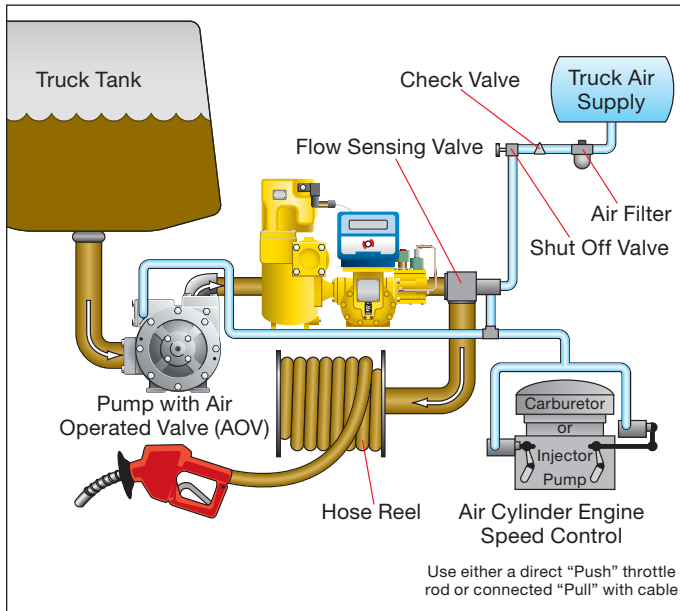

Figure 4: Typical truck delivery system using an AOV.

For pumps equipped with an Air Operated Valve (AOV) assembly, air must be supplied from the truck air system via a flow sensing valve. Approximately 70 psi (4.8 bar) minimum air pressure is required to properly operate the air operated valve. THE AIR PRESSURE MUST NOT EXCEED 125 psi (8.6 bar). The sensing valve should be installed in accordance with the diagram shown in Figure 4. This system depicts the additional use of a throttle control which is optional. All adjustments must be made at normal operating speeds.

- Set the low pressure adjustment first by slowly closing the nozzle to relieve the air pressure in the AOV assembly.
- Remove the AOV cap and O-ring (see [Appendix E](#) for parts details).
- Turn the low pressure adjustment stem counter-clockwise to decrease the bypass pressure and vice versa to increase the pressure.
- Re-install the O-ring and AOV cap and tighten securely.
- Open and close the nozzle several times to ensure proper setting and repeatability.
- Slowly close the delivery nozzle again to relieve the air pressure in the AOV assembly.
- Remove the AOV cap and O-ring.
- Adjust the locknuts clockwise to decrease delivery flow rate and/or pressure and vice versa to increase the flow rate. **NOTE: Make sure the locknuts are**

securely locked against each other before re-installing the adjustment stem cap and O-ring.

- Slowly open the delivery nozzle and note delivery flow rate and/or pressure.
 - Repeat steps g through i until desired flow rate and/or pressure are achieved.
6. The speed of the pump may be increased as long as it increases the flow through the delivery nozzle. It is recommended to turn the pump at approximately 575 RPM for optimum performance. However, the pump can be safely turned to 640 RPM if system conditions permit (refer to [Appendix B](#)).

NOTE: IF PUMP SPEED IS INCREASED, BE CERTAIN THE METER AND PIPING SYSTEM WILL HANDLE THE INCREASED FLOW AND PRESSURE!

Chapter 3–Installation (Stationary)

NOTE: NEW PUMPS CONTAIN RESIDUAL TEST FLUID SO IT MAY BE NECESSARY TO FLUSH THE PUMP PRIOR TO USE. ALL PUMPS SHOULD BE INSTALLED IN AN AREA THAT IS WELL VENTILATED.

The installation of the PT-Series pumps are simple. However, in order for the pump to deliver optimum performance, the principles discussed in this book should be followed. The piping details provided illustrate methods proved by hundreds of installations. Some applications may require light variations, but every effort should be made to follow the recommendations identified in this manual.

The foundation for the pump is important. The foundation must be firm, level, and made of concrete. The suggestions in Figure 5 should be observed.

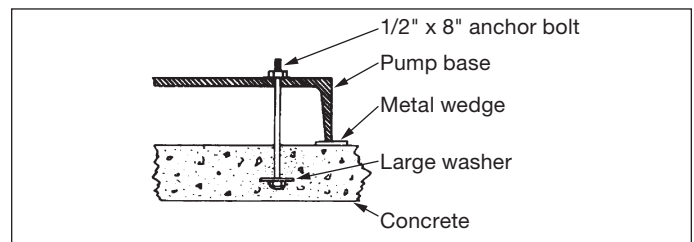

Figure 5

3.1 Coupling alignment

For a long service life, the coupling alignment must be near perfect. **The shaft of the pump and driver are carefully aligned at the factory but should always be checked after the pump is installed and before the initial operation.**

Lay a straight edge across both coupling halves on the top and side. For proper alignment, both coupling faces must be parallel and concentric (figure 1.6).

If misalignment exists, adjust the shims between the pump and baseplate until exact alignment is accomplished.

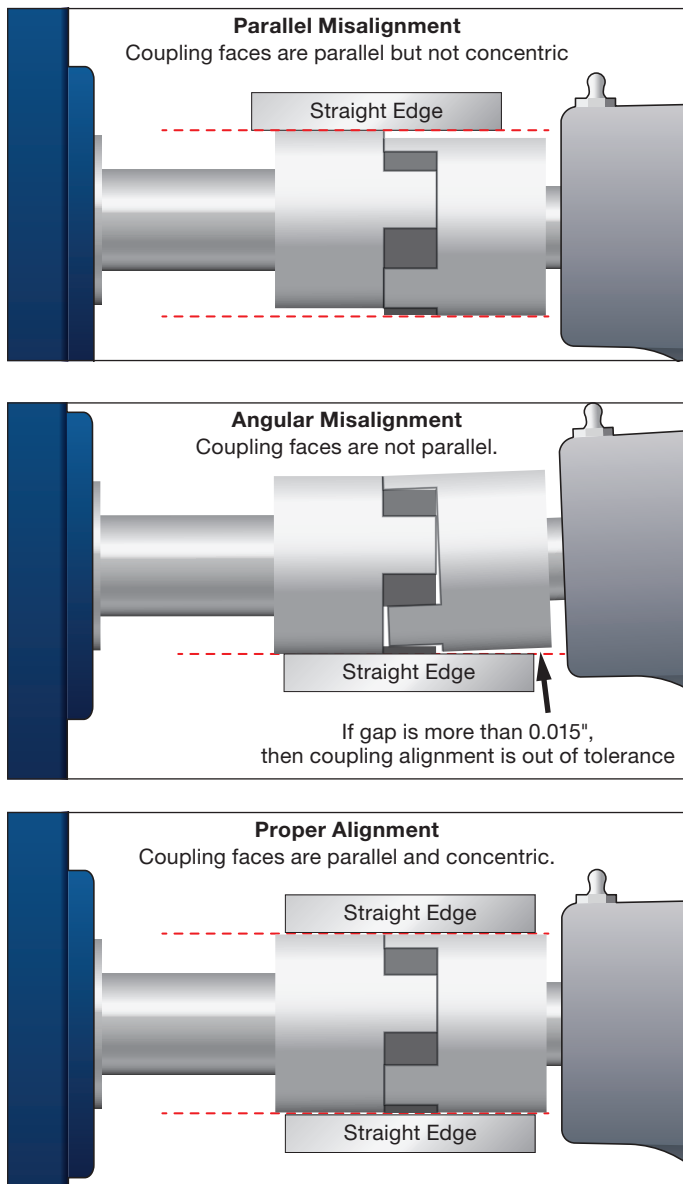

Figure 1.6



Scan QR Code and refer to the maintenance video titled "How to Align the Coupling Between the Motor and Pump".

No pump can discharge more liquid than it receives, so the pump location and the inlet piping must be given careful attention. If the inlet piping is unable to supply the demand of the pump, expect trouble.

The installer and/or the user must take into account the following:

- The pump must be located as near the storage tank as

possible. The complete inlet line, including the vertical line from the tank must not exceed 12 feet (3.7 m) in length.

- The inlet must be the same size or next size larger than the suction on the pump.
- Use an eccentric swage at the pump inlet nozzle to change the line size (flat side up).
- Make certain the inlet line is level or sloped downward to the pump.
- A strainer of the "Y" type, with 20 mesh screen or 1/16 in. perforated steel, must be on the inlet line of the pump. (Mesh size indicates the number of openings per lineal inch).
- Use a flexible connection in the pump inlet and outlet piping to compensate for piping strains.
- The Inlet piping must be free of air leaks.
- All piping must be supported to avoid stress to the pump casing.
- Potential risk due to local conditions regarding the installation and operation (e.g. poor ventilation and additional risks due to other elements in the vicinity, etc.).
- Qualification of the personnel.
- Type of liquid being transferred.
- Specific safety measures to be applied (e.g. gas detection, automatic shut-off valves, personal protective equipment, etc.).

3.2 Driver Installation

Wiring the electric motor correctly is extremely important and must be done by a competent electrical contractor. The following wire sizing chart indicates the minimum standards for wire sizes.

Improper motor wiring causes expensive motor difficulties from low voltage. The motors furnished with the stationary pumps are usually dual voltage. If low voltage is suspected, call the local power company and confirm the voltage provided and wire accordingly. Connecting to improper voltage will completely destroy the motor.

A humid climate can cause problems, particularly in explosion proof motor applications. The normal breathing of the motor, and alternating between being warm when running and cool when stopped, often will cause moist air to be drawn into the motor housing. This moist air will condense, and may eventually add enough free water to the inside of the motor to cause it to fail. To prevent this, make a practice of running the motor and pump at least once a week on a bright, dry day for an hour or so

(pumping through the bypass system). In this period the motor will heat up and vaporize the condensed moisture, and drive it out of the motor. No motor manufacturer will guarantee an explosion-proof or totally enclosed motor against damage from moisture.

Engine drivers pose a special consideration. The manufacturer's instructions must be followed. When the stationary pump is equipped with an engine from the factory, the engine speed should normally not exceed 1,800 RPM. Excessive engine speed will overload the engine and cause early failure. The engine loses 3% of its power for every 1,000 ft (305 m) above sea level, so if the installation is at a higher altitude than normal, consult the factory.

Motor				Recommended wire size, AWG ¹		
Hp	Motor phase	Volts	Approximate full load amperes	Length of run (ft)		
				0-100	to 200	to 300
3	1	115	34.0	6	4	2
		220	17.0	12	8	8
	3	230	9.6	12	12	12
		460	4.8	12	12	12
5	1	115	56.0	4	1	1/0
		230	28.0	10	6	4
	3	230	15.2	12	12	10
		460	7.6	12	12	12
7-1/2	1	230	40.0	8	6	4
		230	22.0	10	10	8
	3	450	11.0	12	12	12
10	3	230	28.0	8	8	8
		460	14.0	12	12	12
15	3	230	42.0	6	6	6
		460	21.0	10	10	10
20	3	230	54.0	4	4	4
		460	27.0	8	8	8
25	3	230	68.0	2	2	2
		460	34.0	6	6	6
30	3	230	80.0	1	1	1
		460	40.0	6	6	6
40	3	230	100.0	2/0	2/0	2/0
		460	52.0	4	4	4
50	3	230	130.0	3/0	3/0	3/0
		460	65.0	2	2	2

¹ Based upon 3% voltage loss copper wire type TW. Single phase motor calculations are based on two times distance.

Chapter 4—Operation (Stationary)

Performance curves are provided in [Appendix C](#).

The following steps should be performed for the initial pumping operation:

1. Make sure the strainer screen is clean.
2. Rotate the pump by hand.
3. Check V-belt drive or direct drive coupling alignment.

Misalignment will accelerate wear on the drive system, motor bearings and pump.

4. Check motor for proper wiring.
5. Review complete system to make certain the function of every valve and piece of equipment is clearly understood. Everyone operating this system must be properly trained in normal operating procedures and emergency procedures in the event of a malfunction.
6. Close all hose valves.
7. Slowly open the storage tank bottom shut-off valve (suction line to the pump). Immediately check the system for leaks.
9. Record all pressure gauge readings, especially the pressure gauge located at the discharge of the pump. Start the pump and circulate the liquid through the internal bypass valve.
10. Verify the proper pump rotation direction by referring to the part details in [Appendix E](#) or the "Pump Rotation" section at the beginning of this manual.
11. The pump has an internal bypass valve so it must be adjusted to the required setting. The internal bypass valve may be adjusted while the pump is in operation by removing the bypass valve cap. Turning the adjusting screw clockwise increases the internal bypass valve pressure setting and counterclockwise decreases the pressure setting.
12. An amp meter may be used by adjusting the bypass valve until the amp meter indicates the full load motor amperage rating shown on the motor nameplate or maximum rated differential, whichever comes first. If the motor overload protection device stops the motor in this period the bypass valve setting is too high and should be readjusted. After a satisfactory setting is achieved, "seal" the bypass valve cap to prevent tampering with the adjustment.
13. After initial operation, re-check the strainer screen.

Chapter 5—Maintenance of the Pump System

PT-Series pumps require regular maintenance and care like all mechanical equipment. A neglected or improperly repaired pump will result in premature failure and cause unsafe conditions. To promote product longevity and safety, maintenance must be performed by properly trained technicians. Make sure all safety systems are in place and the system pressure has been relieved before attempting ANY maintenance.

Normal wear parts are the mechanical shaft seals, bearings, vanes, vane drivers and sideplates. All of these parts plus O-rings and grease seals are offered in the "repair kit." Use only genuine Corken replacement

parts when repairing the PT-Series pumps. Follow the instructions provided with the parts.

When it becomes necessary to repair the pump or remove it from the system, be absolutely certain that all product being pumped is bled from the pump and connected piping. Once all the product has safely been bled from the pump and connected piping, make certain no pressure is left in the system. **SPECIAL CARE MUST BE TAKEN DURING THE BLEED DOWN PROCESS TO AVOID DANGER TO PERSONNEL AND PROPERTY IN THE AREA.** Take extra time to bleed the system and make proper provisions to capture the product in accordance with local regulations. **ONLY A PROPERLY TRAINED INDIVIDUAL SHOULD BE ALLOWED TO BLEED A PUMPING SYSTEM.**

5.1 Pump Maintenance Schedule

Make sure the transfer hoses are not “kinked”. A kinked hose can cause excessive pump discharge pressure. Always make sure the hoses are not out of date.

	Daily	Monthly	3 Months
Lubricate bearings		•	
Inspect drive coupling			•
Clean inlet strainer		•	
Check for leaks	•		
Inspect hose and fittings	•		

5.2 Bearing Lubrication

NOTICE: AVOID ENTANGLEMENT IN MOVING PARTS. DO NOT LUBRICATE PUMP BEARINGS, HYDRAULIC ADAPTER COUPLING OR ANY OTHER PARTS WHILE THE PUMP IS ACTIVE.

There are two lubrication points in which to grease the pump bearings; one zerk per bearing cap located at opposite ends of the pump. Two grease relief and ventilation fittings have been provided—one at each end of the pump—to help prevent over greasing the bearings. Over greasing can cause seal failure if grease passageways are blocked in some way. Remove relief fittings or confirm free movement of relief prior to greasing bearings. Clean each fitting before lubricating the bearings. This practice helps to prevent foreign material contamination of the bearings and accidental over-pressurization of the mechanical seals. Use only NLGI grade 2 ball bearing grease.

Lubricate ball bearings and hydraulic motor couplings (if equipped) a minimum of every three months.

Greasing Procedure:

1. Remove grease relief fittings from bearing covers or hydraulic motor adapter.

2. Grease with a hand gun until grease escapes from grease relief fitting port.

3. Return grease relief fittings to bearing covers.

DO NOT over grease pump bearings. Some grease will escape from the grease tell-tale hole after lubrication. This is normal, but excessive grease on pumps that use mechanical seals can cause seal failure.

5.4 Strainers

Clean strainers regularly to avoid pump starvation. Intervals between cleaning depend upon the application and conditions.

5.5 Disassembly Instructions

1. Truck engine must be turned off and PTO disengaged.
2. Bleed all product from the system as described above. **NOTE:** There is a 1/4 in. NPT connection at the bottom of some models that allow easy pump drainage.
3. Remove the PTO shaft or hydraulic drive motor, adapter, and coupling.

NOTICE: ADHERE CLOSELY TO ALL HAZARD WARNINGS AND INSTRUCTIONS IN THE “MAINTENANCE” SECTION OF THIS MANUAL.

4. Carefully clean the pump shaft. Begin at one end of the pump, and make certain that the shaft is free of nicks and burrs to prevent damage to the mechanical seal when removing the head assembly.
5. Unscrew the bearing cover bolts and pull the bearing cover and gasket off the shaft. Dispose of the bearing cover gasket.
6. Unscrew the opposite bearing cover bolts and pull the bearing cover and gasket off the shaft. Dispose of the bearing cover gasket.
7. Remove the locknuts and lockwashers in place:
 - a. Bend the lockwasher tab up and unscrew the locknut counterclockwise and remove it from the shaft.
 - b. Pull the lockwasher off the shaft. Check the lockwasher for damage and replace if needed.
 - c. Repeat steps a and b on the opposite end of the shaft.
8. Unscrew the head bolts and carefully pry the head from the pump casing.

9. Pull the head off the shaft. The head O-ring, bearing and mechanical seal will come off with the head assembly. Detach and dispose of the head O-ring.
 - a. Take the bearing out of the housing in the head.
 - b. Remove the mechanical seal. Using two screwdrivers, gently push the backside of the seal jacket to remove the seal from the head (see Figure 7). Be careful when using the screwdrivers on the seal faces. The seal faces can be damaged. Detach and dispose of the mechanical seal O-rings.

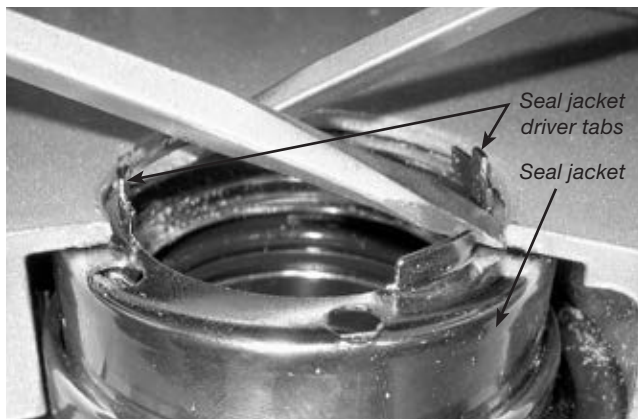
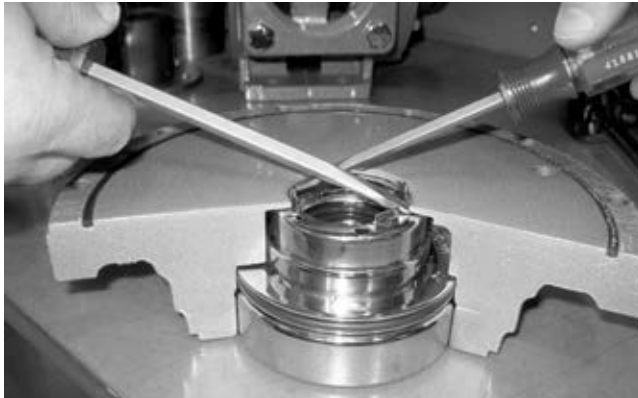

Figure 7

10. Remove the rotor and shaft from the pump casing. While removing the shaft, cup one hand underneath the rotor so the vanes and vane drivers do not fall out. Carefully set aside the rotor and shaft, vanes and vane drivers for future reassembly.
11. Repeat steps 8 and 9 above to remove the remaining components from the opposite side of the pump.

5.6 Assembly Instructions

Before reassembly, check each component part for wear or damage. If necessary, replace flawed parts. Wash out the bearing/seal recess of the head and remove any burrs or nicks from the rotor and shaft.

1. Reassemble the first side of the pump by inserting a new head O-ring into the groove of the head. Lightly lubricate the O-ring to facilitate installation. Start on one side of the groove and stretch the O-ring into the groove (see Figure 8).



Figure 8

2. Attach the head to the pump casing. Insert four head bolts 90° apart and tighten to 25 ft•lbs (34 Nm).

3. Mechanical Seal

Apply a small amount of light oil in the head recess. Press the mechanical seal assembly into the recess of the head so the seal jacket drive tabs face the rotor. The pin in the stationary seat must be between the lugs in the back of the head recess (see Figure 7).

4. Hand pack the ball bearing with grease. See the “Bearing Lubrication” section for recommended grease.
5. Insert the bearing into the head recess. The bearing balls should face outward, and the grease shield should face inward. Make sure the bearing is square and completely seated against the mechanical seal.
6. Turn the pump casing around to reassemble the opposite side.
7. Place vanes into the upper rotor-shaft slots. Ensure the curved tip of each vane faces radially outward and all in the same direction of rotation (see Figure 10).
8. While cupping these vanes in place, rotate the rotor-shaft over 180° and install the vane drivers.
9. Place rotor-shaft and vane assembly into pump case with the vanes on the bottom. Ensure the ribs in the vanes face the direction of pump rotation (see [Appendix E](#) for parts details and pump rotation arrows).
10. Place the remaining vanes into the upper rotor-shaft slots facing the same direction as the first vanes.

11. Install the remaining head, mechanical seal, and bearing as mentioned in steps 1 through 5. Apply a thin coating of motor oil to the shaft to facilitate installation.
12. Rotate the shaft by hand to engage the seal jacket driver tabs. Check for binding or tight spots. If the rotor does not turn freely, use a soft faced mallet and lightly tap the rims of the heads until the rotor is in the correct position. Tighten all remaining head bolts for each head to 25 ft•lbs (34 Nm) of torque.
13. Locknut Installation

All bearing locknuts and lockwashers **MUST** be positioned and adjusted properly. Overtightening locknuts can lead to bearing failure or broken lockwasher tabs. If locknuts are loose, the rotor will shift against the heads and cause considerable wear (see Figure 9).

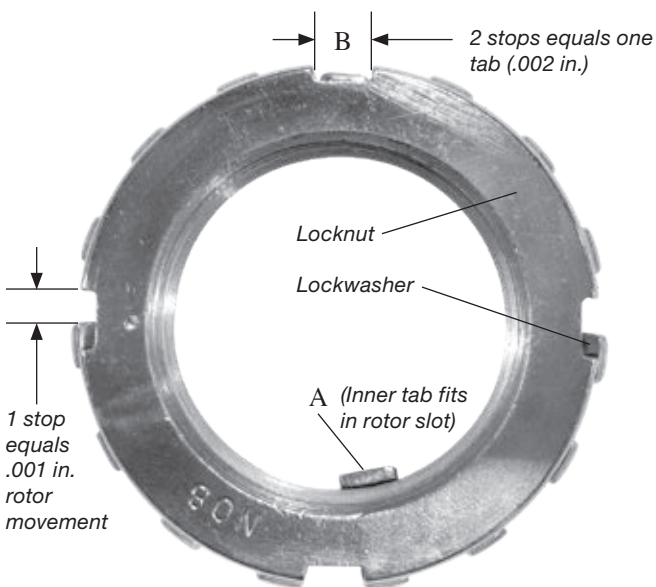

Figure 9: Locknut and lockwasher adjustment

- a. On both ends of the pump shaft, slide on a lockwasher, with the tabs facing outward, and then tighten a locknut with the tapered end inward. Make sure the inner tab (A) of the lockwasher is inserted in the slot of the shaft threads. Bend slightly, if necessary.
- b. Carefully tighten both locknuts until the bearings have reached the bottom of the head recess. **DO NOT** overtighten, Make sure the inner tab of the lockwasher does not shear.
- c. Loosen both locknuts one complete turn.
- d. Tighten one locknut until a slight rotor drag can be felt while turning the shaft by hand.
- e. Back the locknut off one width of the lockwasher tab (B). To secure the locknut, bend the closest aligned lockwasher tab into the slot of the locknut. The pump should now turn freely when rotated by hand.

- f. Hand-tighten the opposite locknut until it is snug against the bearing. Then, with a spanner wrench, tighten the locknut one width of the lockwasher tab. Tighten just past the tab width and then back off the locknut until the tab is aligned with the slot of the locknut. To secure the locknut, bend the aligned lockwasher tab into the slot of the locknut. The pump should still turn freely when rotated by hand.
- g. Check the adjustment. The locknut and lockwasher should turn back and forth by hand. If this is not possible, one or both locknuts are too tight. They must be alternately loosened one stop at a time (.001 in.) (25 microns). Begin with the locknut adjusted last.

14. If equipped with the standard bypass valve, remove the bypass valve cap and turn the adjustment screw counterclockwise to relieve the spring tension. Remove the four 3/8 in. bolts from the bypass valve cover. **Use caution as a small amount of spring tension will remain on the bypass valve spring before complete bolt removal.** Inspect bypass valve, spring, and bypass valve cap gasket for wear, abrasions, etc. Replace if damage is found.

15. If equipped with an Air Operated Valve (AOV), ensure the air supply pressure has been relieved and the supply line disconnected from the valve housing. Remove the AOV cap and discard the O-ring from underneath. Remove the retainer ring and locknuts from the adjustment stem. Remove the four 3/8 in. bolts and lockwashers from the AOV housing. Carefully remove the AOV assembly from the pump. Remove and discard the gasket and clean the gasket areas. Remove the two recessed-head machine screws and the diaphragm cover plate. Slide the diaphragm assembly out from the housing. Remove the intermediate vent plate from between the two diaphragms. Inspect the diaphragms, spring, and valve for abrasions and replace if necessary.

5.7 Vane Replacement

NOTICE: ONLY QUALIFIED TECHNICIANS SHOULD PERFORM MAINTENANCE AND THEY MUST FOLLOW THE APPROPRIATE PROCEDURES AND WARNINGS PRESENTED IN MANUAL.

1. Follow steps 2–6 in the “Pump Disassembly Instructions” section of this manual to remove the head assembly from the non-PTO side of the pump.
2. Rotate the shaft until a vane is in the top (12 o’clock) position of the rotor. Remove the vane.
3. Position a new vane so the rounded edge faces out from the pump and the relief grooves face towards the direction of rotation (see Figure 10).

4. Repeat steps 2 and 3 until all vanes have been replaced.
 5. Follow steps 2–7 and 12–13 of the “Pump Assembly Instructions” section of this manual to reassemble the pump.
2. Grease bearings per the instructions listed in the Pump Maintenance schedule.
 3. Install the pump according to the installation guidelines mentioned previously.

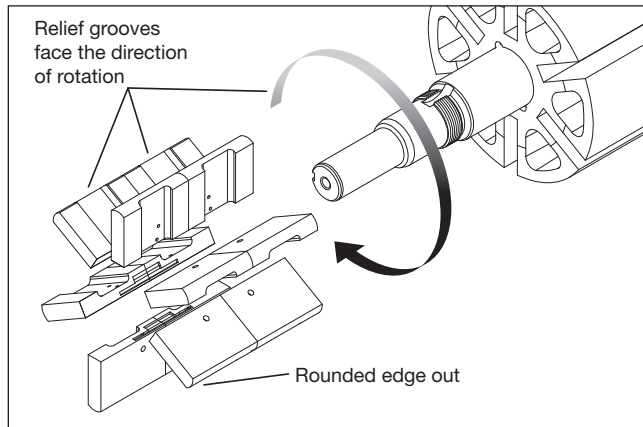

Figure 10: PT30 model shown above

5.8 Bypass Valve Assembly

1. Place the bypass valve into the bypass valve bore of the pump casing with the fluted end inward.
2. Insert the bypass valve spring and spring guide against the bypass valve.
3. Attach a new bypass valve gasket and the bypass valve cover onto the pump casing.
4. Tighten the bypass valve adjusting screw into the bypass valve cover until it makes contact with the spring guide.

NOTICE: THE BYPASS VALVE SETTING MUST BE TESTED AND PROPERLY ADJUSTED BEFORE PUTTING THE PUMP INTO SERVICE. PLEASE SEE “BYPASS VALVE ADJUSTMENT”.

5. After the bypass valve has been adjusted correctly, attach the bypass valve cap and gasket.

5.9 Air Operated Valve (AOV) Assembly

1. Install the intermediate vent plate between the two diaphragms ensuring proper orientation with the screw holes in the housing. Slide the diaphragm assembly into the housing and install the diaphragm cover plate and recessed-head machine screws and tighten securely. Install this assembly with the valve, spring, and gasket to the pump using the four 3/8 in. bolts and lock washers and torque to 15 ft•lbs. Install both locknuts all the way down the adjustment stem and replace the retainer ring. Install the new O-ring and AOV cap. Refer to Air Operated Valve Adjustment for adjustment procedure.

Chapter 6–Repair Kits

PT20 Repair Kit 4771-X1_2^a

Part Number	Description	Qty.
2-258 ^a	O-ring	2
4648	Ball bearing	2
4678	Vane driver	2
4677	Vane	4
4634-X_2 ^a	Seal assembly	2
4654	Shaft lockwasher	2
4655	Shaft locknut	2
4650	Grease seal	2
4657	Bearing cap gasket	2
4688	Flange gasket	2
4659	Bypass valve cap gasket	1
4767	Bypass valve cover gasket	1
4653	Shaft key	1
ID108	I.O.M. manual	1

PT30 Repair Kit 4769-X1_2^a

Part Number	Description	Qty.
2-266 ^a	O-ring	2
5584	Ball bearing	2
5589	Vane driver	3
5588	Vane	6
4621-X_2 ^a	Seal assembly	2
5591	Shaft lockwasher	2
5592	Shaft locknut	2
5586	Grease seal	2
5596	Flange gasket	2
5595	Bearing cap gasket	2
5597	Bypass valve cap gasket	1
5578	Bypass valve cover gasket	1
2270	Shaft key	1
ID108	I.O.M. manual	1

PT25 Repair Kit 4770-X1_2^a

Part Number	Description	Qty.
2-258 ^a	O-ring	2
4648	Ball bearing	2
4652	Vane driver	3
4696	Vane	6
4634-X_2 ^a	Seal assembly	2
4654	Shaft lockwasher	2
4655	Shaft locknut	2
4650	Grease seal	2
4657	Bearing cap gasket	2
4658	Flange gasket	2
4659	Bypass valve cap gasket	1
4660	Bypass valve cover gasket	1
4653	Shaft key	1
ID108	I.O.M. manual	1

^a See material code chart.

^b Registered trademark of the DuPont company.

Material Code	
A	Buna-N
D	Viton ^{®b}

Appendix A—Model Number Identification Code and Available Options

PT-Series (Double Shaft)

Base Model	PT20	PT25	PT30	
Base Model (with hydraulic drive option)	PTH20	PTH25	PTH30	

Specification Fields

Specification Field	Option	Standard	Standard	Standard	Code
Strainer	No strainer	Standard	Standard	Standard	N
	With strainer	Option	Option	Option	S
Internal Bypass Valve	Bypass valve	Standard	Standard	Standard	S
	Air Operated Valve (AOV)	Option	Option	Option	A
Bypass Valve Spring	35–50 psi	Option	Not applicable	Not applicable	4
	50–75 psi	Option	Not applicable	Not applicable	1
	75–110 psi	Standard	Not applicable	Not applicable	2
	110–125 psi	Option	Not applicable	Not applicable	3
	50–110 psi	Not applicable	Standard	Standard	2
	110–125 psi	Not applicable	Option	Option	3
Seal O-ring Material	Buna-N	Standard	Standard	Standard	A
	Viton ^{®a}	Option	Option	Option	D
Seal Seat Material	Cast iron	Standard	Standard	Standard	2
Inlet Flange	2 in. NPT	Standard	Optional	Not applicable	E
	2.5 in. NPT	Not applicable	Standard	Not applicable	J
	3 in. NPT	Not applicable	Not applicable	Standard	P
	2 in. weld	Optional	Not applicable	Not applicable	F
	2.5 in. weld	Not applicable	Optional	Not applicable	K
	3 in. weld	Not applicable	Not applicable	Optional	Q
	Less flange	Optional	Optional	Optional	X
Outlet Flange	2 in. NPT	Standard	Optional	Not applicable	E
	2.5 in. NPT	Not applicable	Standard	Not applicable	J
	3 in. NPT	Not applicable	Not applicable	Standard	P
	2 in. weld	Optional	Not applicable	Not applicable	F
	2.5 in. weld	Not applicable	Optional	Not applicable	K
	3 in. weld	Not applicable	Not applicable	Optional	Q
	Less flange	Optional	Optional	Optional	X

Strainer Assembly^b

Pump Model	Strainer Assembly Part Number
PT/PTH20	4684-X
PT/PTH25	4689-X
PT/PTH30	4680-X

Air Operated Valve Assembly (AOV)

Pump Model	AOV Part Number
PT/PTH20	5470-1XA (Buna-N)
PT/PTH25	5462-1XA (Buna-N)
PT/PTH30	5566-1XA (Buna-N)

^a Registered trademark of the DuPont company.

^b Strainer assembly ordered by part number when not assembled to the pump.

Appendix B—Specifications

Operating Specifications

Standard connections:	2 in., 2-1/2 in., and 3 in. NPT
Optional connections:	Slip-on weld
Maximum differential pressure:	125 psid (8.6 bar)
Temperature range:	-25° to 300°F (-32° to 149°C)
Maximum working pressure:	200 psi (13.8 bar)
Maximum speed:	780 RPM—all models 20 and 25
	640 RPM—all models 30
Maximum flow:	Up to 271 GPM (1,026 L/min)
Maximum viscosity:	20,000 SSU (4,250 cP)
Fluids:	Refined petroleum products, industrial solvents, and other fluids

Material Specifications

Part	Standard Material	Optional Material
Case	Cast iron ASTM A48	
Head	Cast iron ASTM A48	
Flanges	Cast iron ASTM A48	
Rotor	Ductile iron ASTM A536	
Bearing cap	Steel	Bearing cover / spacer with hydraulic motor adapter (cast aluminum) and coupling (steel)
Bearings	Ball (single row), grease lubricated to 300°F (149°C) Max.	
Vanes	Full size with 316 stainless steel wear plate to 240°F (115°C); 20,000 SSU (4,250 cP) max.	
Bypass valve	Cast iron ASTM A48 electroless nickel plated	
Bypass/AOV cap	Cast iron ASTM A48	
Bypass valve cover	Cast iron ASTM A48	
Bypass valve spring	Plated steel	
Bypass valve spring ranges	35–125 psi (2.4–8.6 bar)	
Seal seat	Cast iron	Stainless steel and Ni-Resist
Seal metal parts	Steel	
Shaft	Keyed shaft, high strength steel	
O-rings	Buna-N to 240°F (115°C)	Viton ^{®2} to 300°F (149°C)
Gaskets	Composition to 500°F (260°C)	
Vane drivers	Case hardened steel	
Gage ports	1/4 in. NPT	

¹ Registered trademark of the DuPont company.

Appendix C—Performance Curves

PT/PTH20 Pump ¹

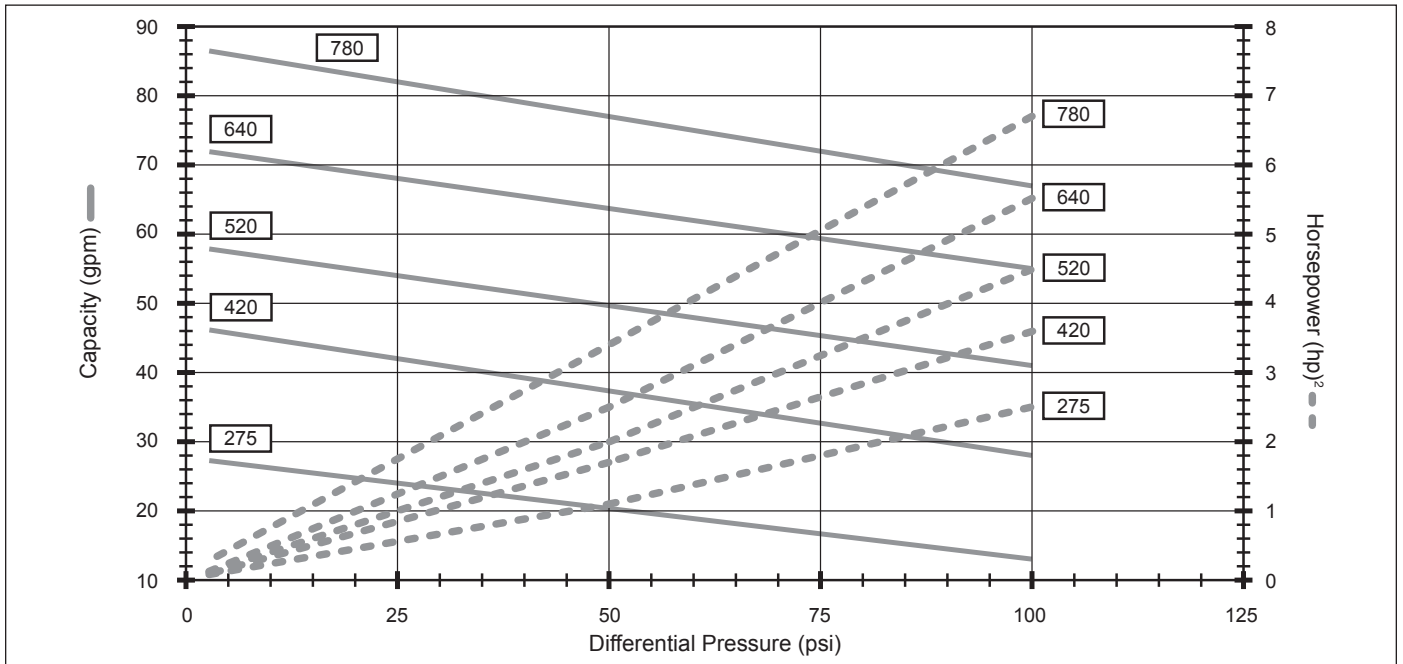

PT/PTH25 Pump ¹

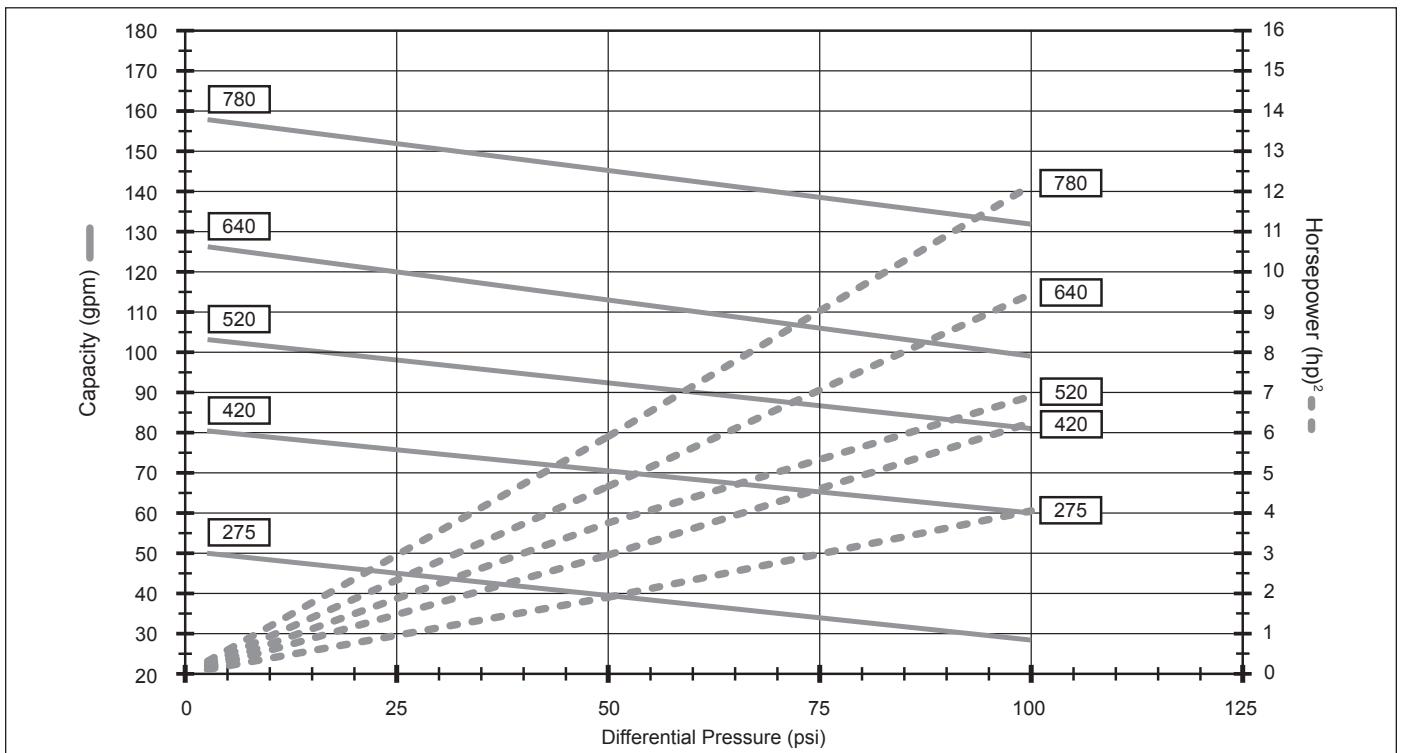

Viscosity Chart

Viscosity (SSU)	100	1,000	5,000	10,000	20,000
Maximum RPM	780	640	520	420	275

¹ These curves depict performance of the PUMP ONLY. Performance will vary in applications due to system design and variables. Approximate capacities and horsepowers are based on 30 SSU (3 cP) fluid.

² Torque (in•lb) = $\frac{hp \times 63025}{RPM}$

Appendix C—Performance Curves

PT/PTH30 Pump ¹

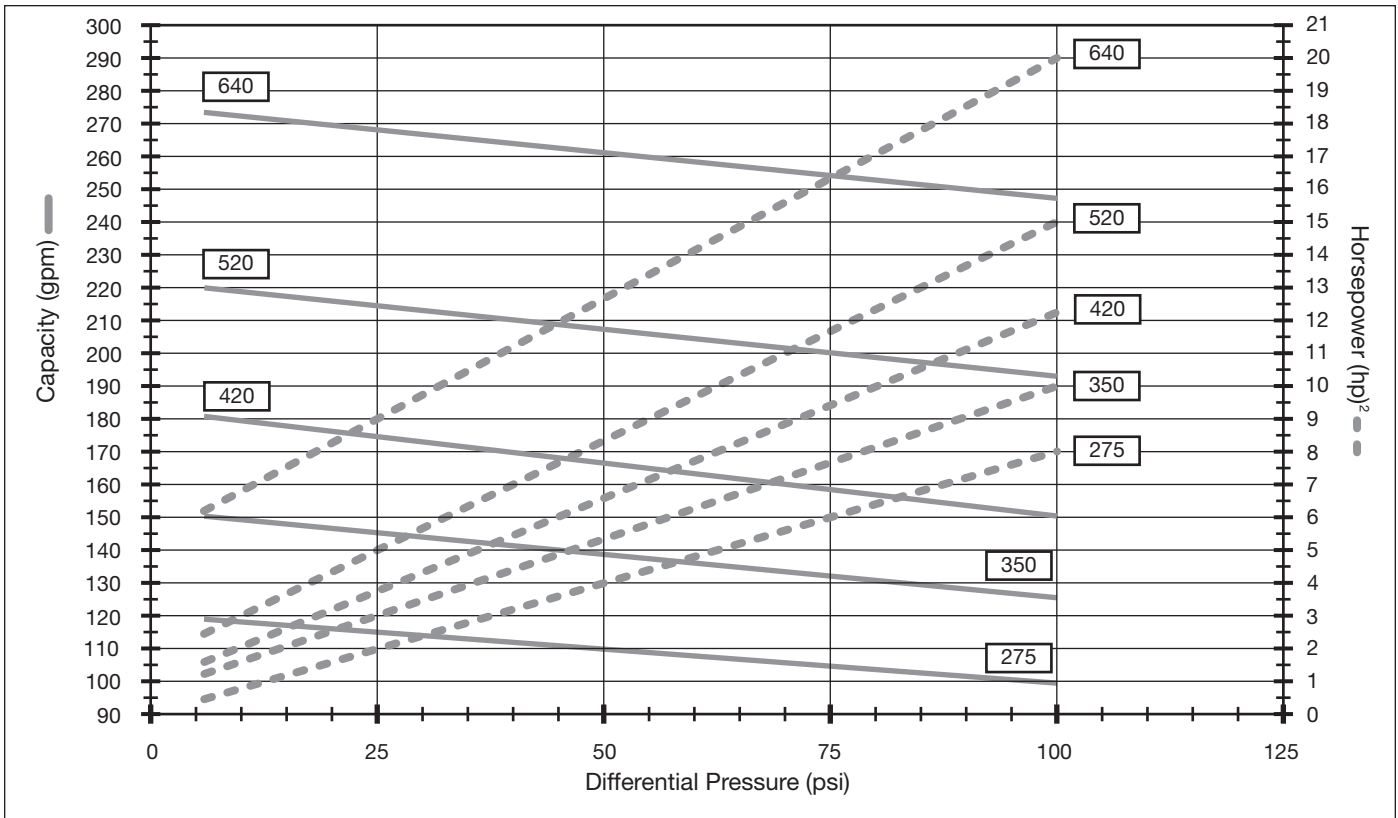

Viscosity Chart

Viscosity (SSU)	100	1,000	5,000	10,000	20,000
Maximum RPM	780	640	520	420	275

¹ These curves depict performance of the PUMP ONLY. Performance will vary in applications due to system design and variables. Approximate capacities and horsepowers are based on 30 SSU (3 cP) fluid.

² Torque (in•lb) = $\frac{hp \times 63025}{RPM}$

Appendix D—Outline Dimensions for the PT30

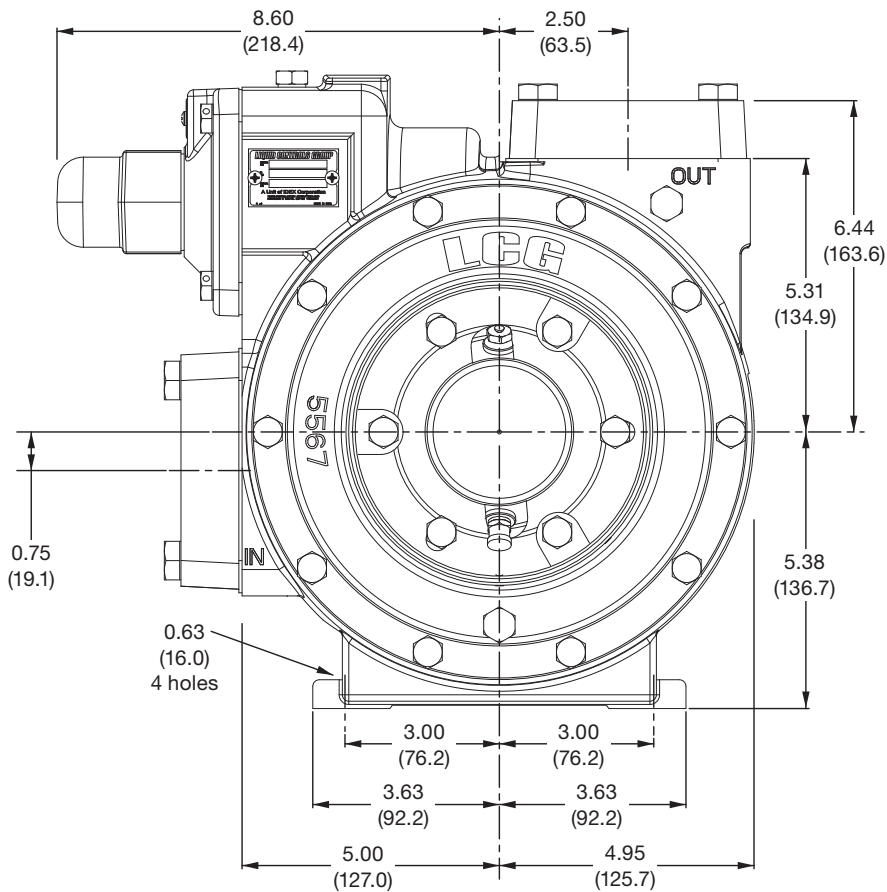
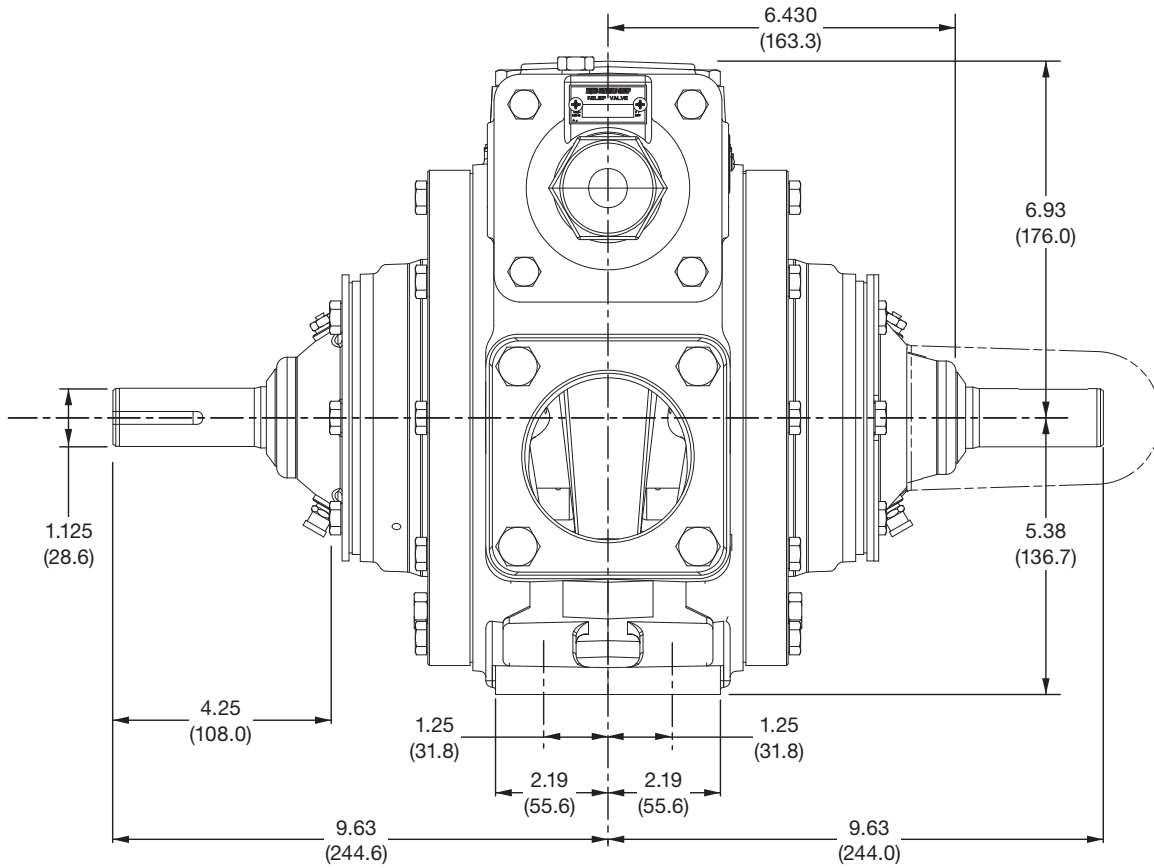

All dimensions are in inches (millimeters).

Appendix D—Outline Dimensions for Air Operated Valve and Strainer

5470-1XA Air Operated Valve (AOV) Assembly for PT/PTH20 Pumps

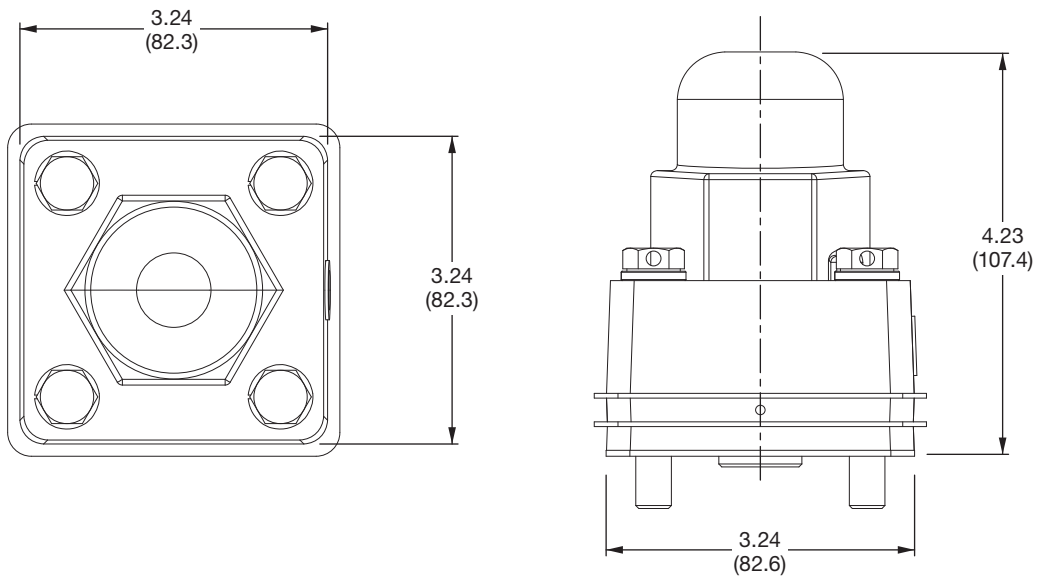

4684-X Strainer Assembly for the PT/PTH20 Pumps

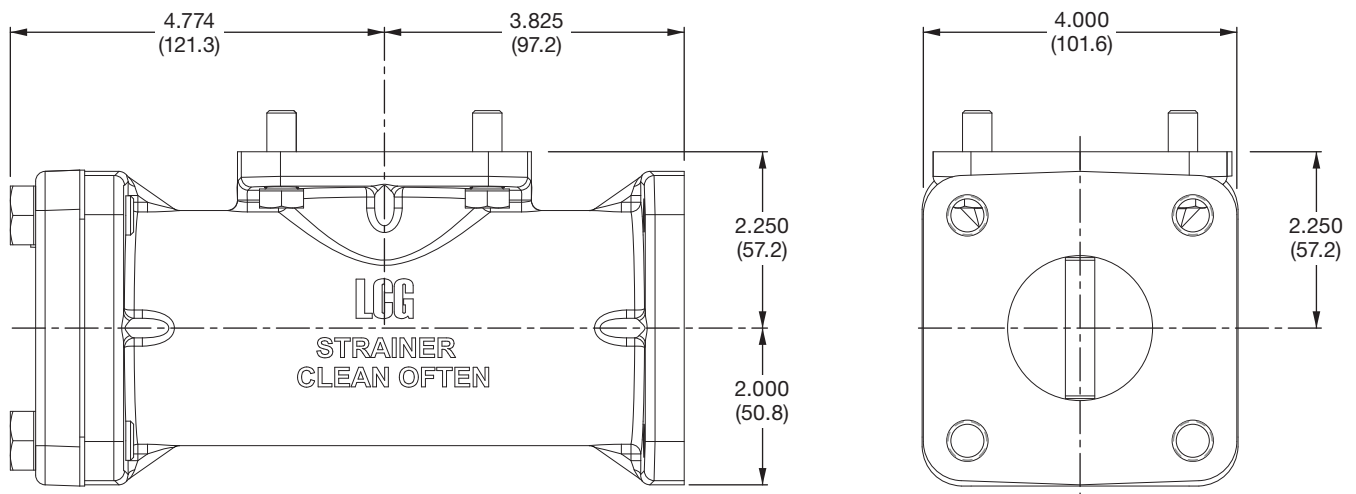

All dimensions are in inches (millimeters).

Appendix D—Outline Dimensions for Air Operated Valve and Strainer

5462-1XA Air Operated Valve (AOV) Assembly for PT/PTH25 Pumps

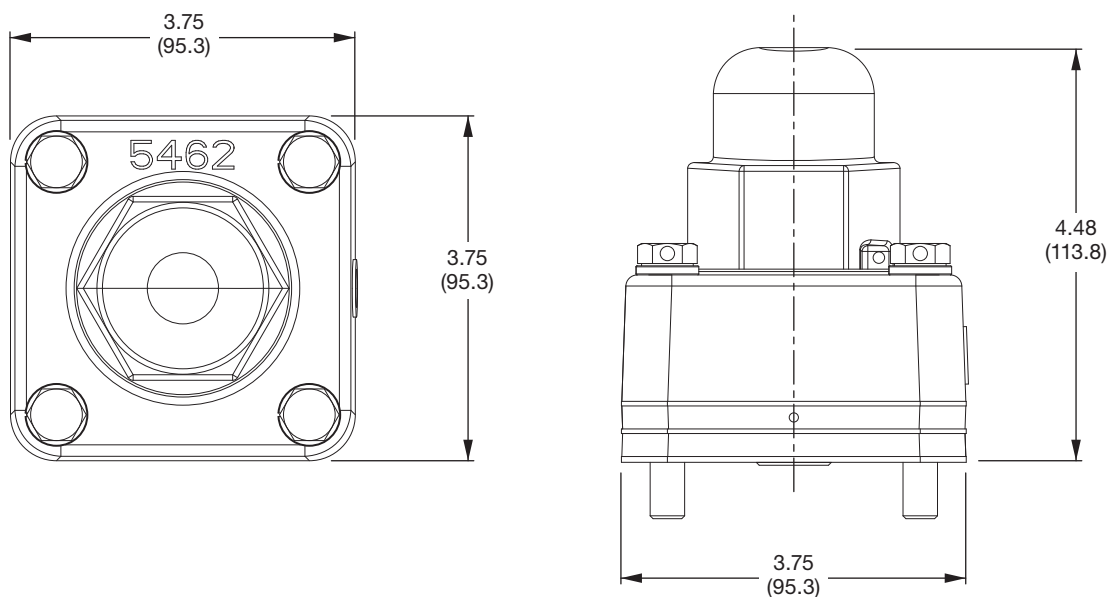

4689-X Strainer Assembly for the PT/PTH25 Pumps

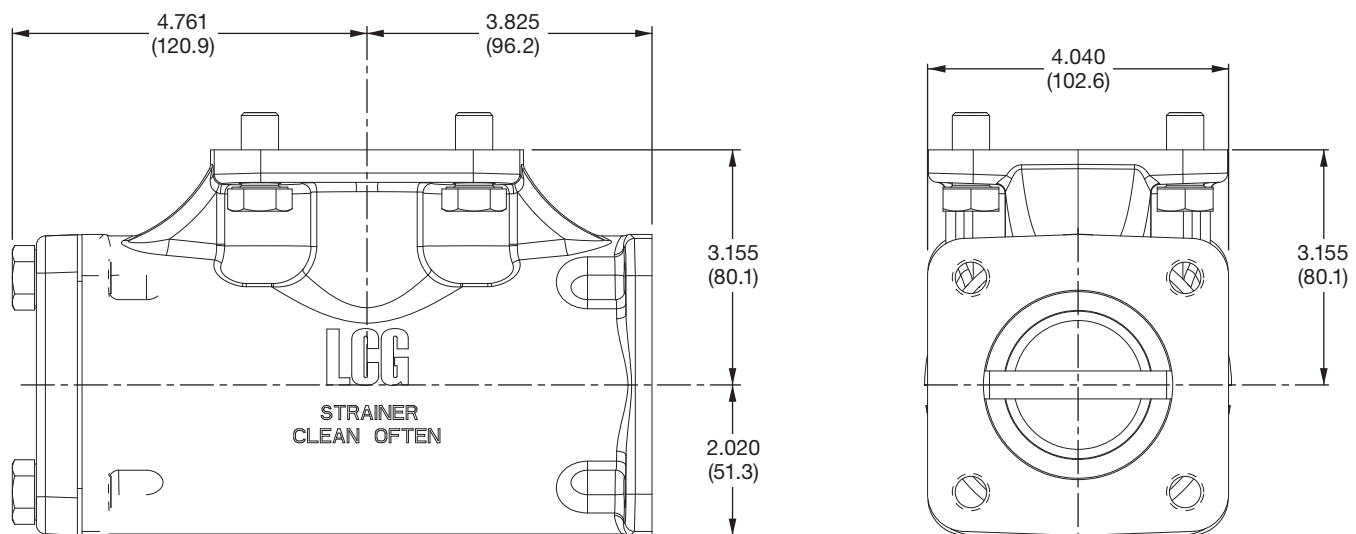

All dimensions are in inches (millimeters).

Appendix D—Outline Dimensions for Air Operated Valve and Strainer

5566-XA Air Operated Valve (AOV) Assembly for PT/PTH30 Pumps

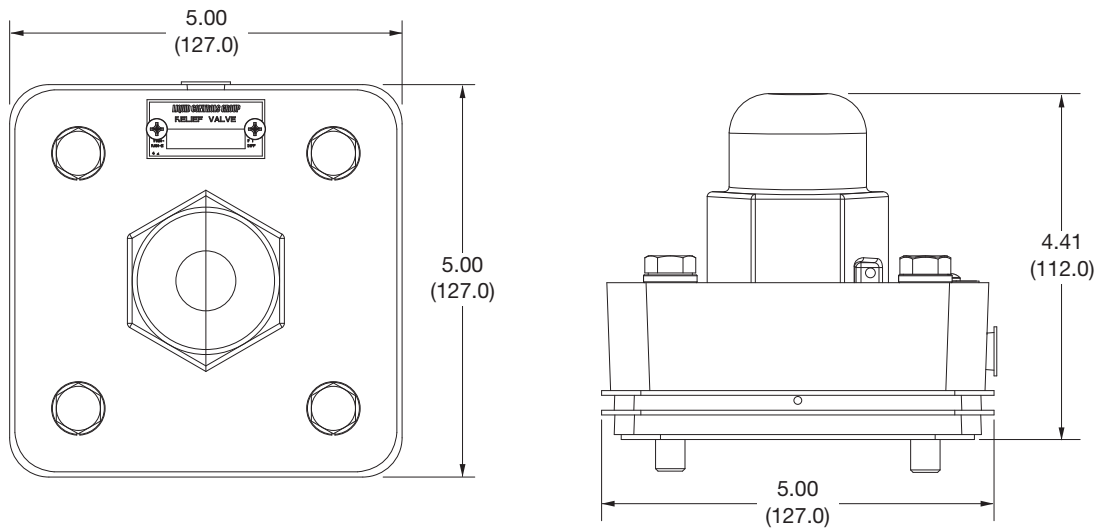

4680-X Strainer Assembly for the PT/PTH30 Pumps

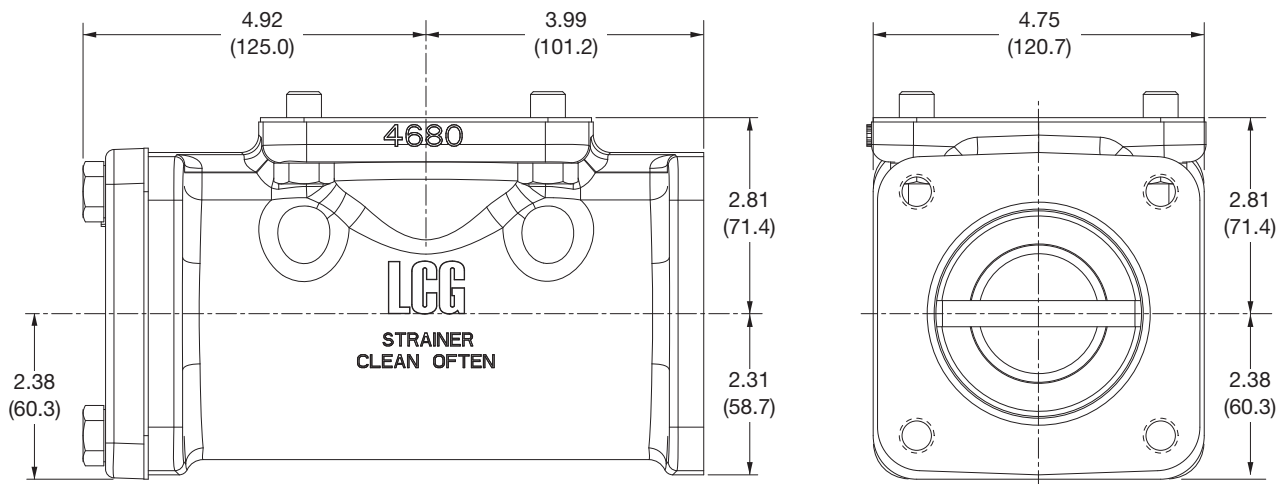

All dimensions are in inches (millimeters).

Appendix D—Outline Dimensions for Hydraulic Drive Option

PTH20 Pump

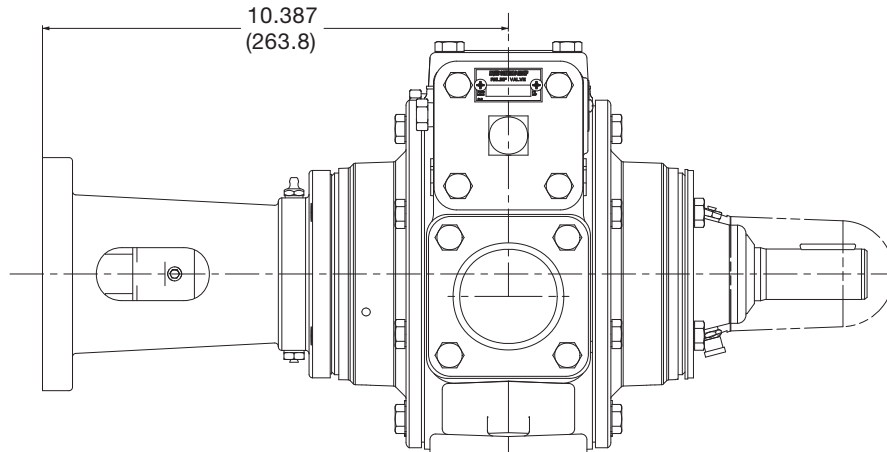

PTH25 Pump

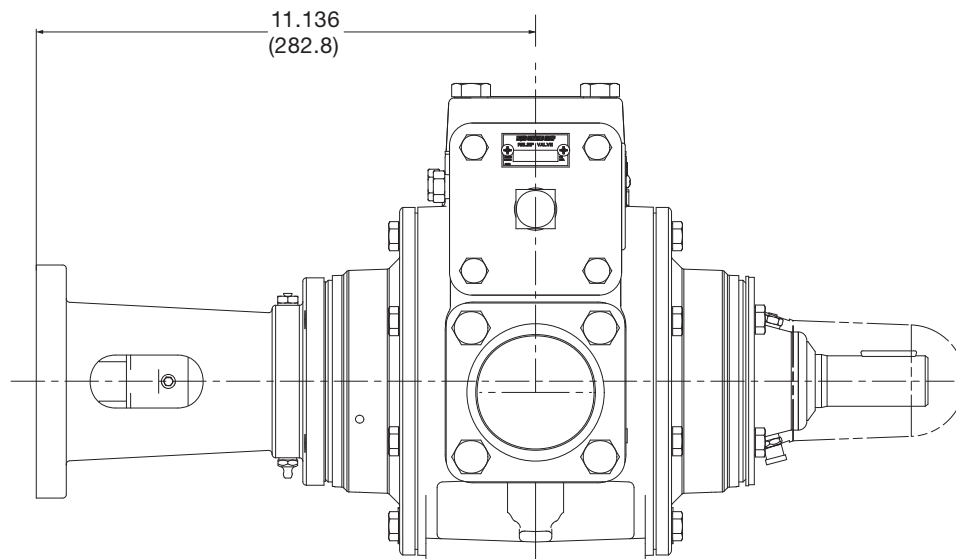

PTH30 Pump

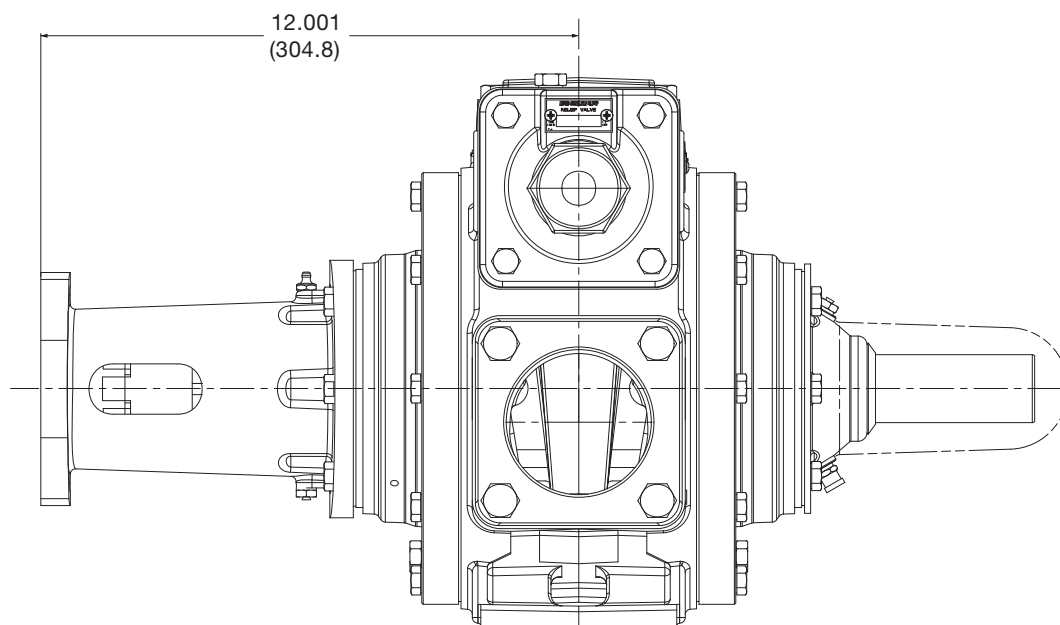

All dimensions are in inches (millimeters).

Appendix E—Part Details for the PT20 with Standard Bypass Valve

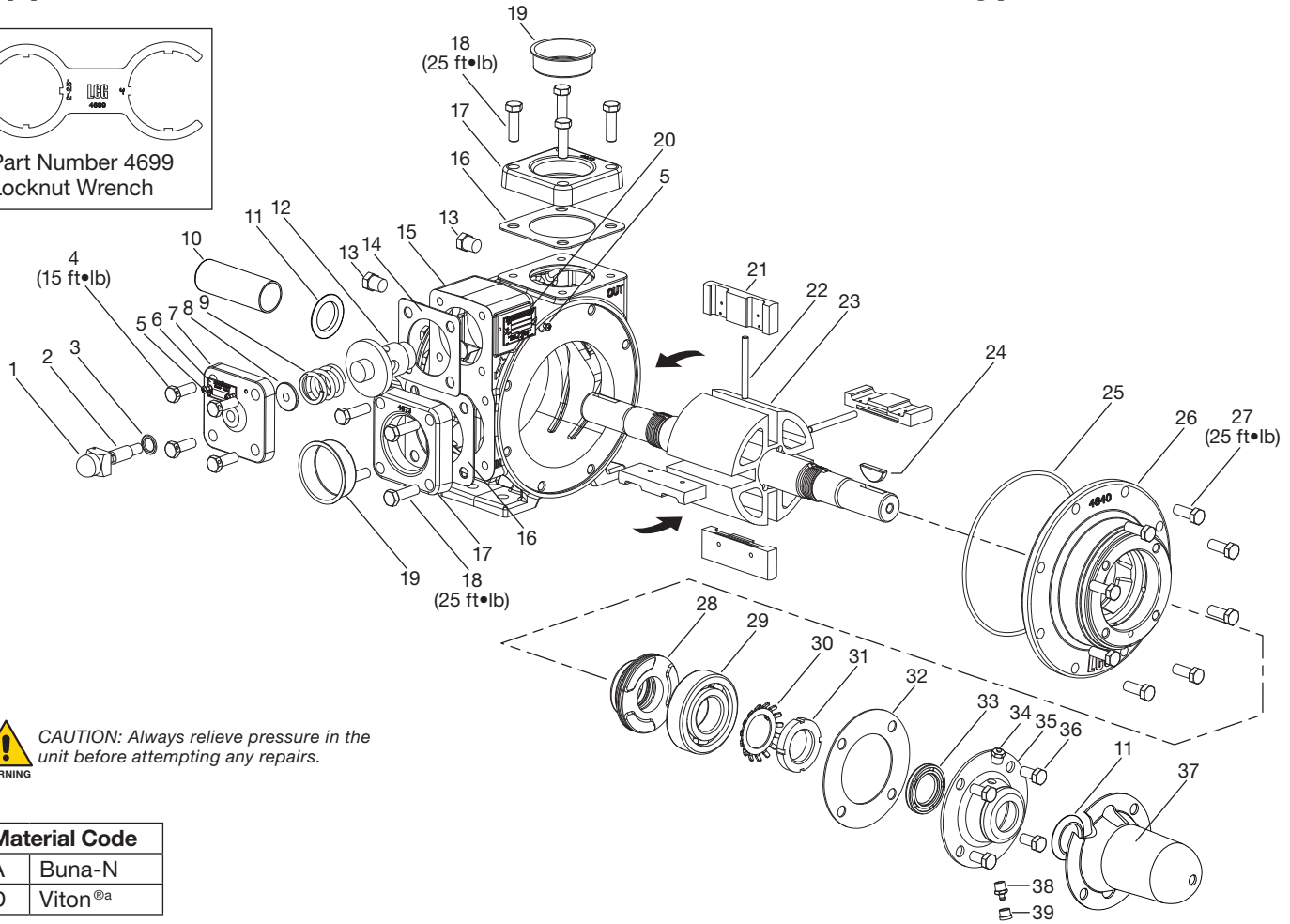
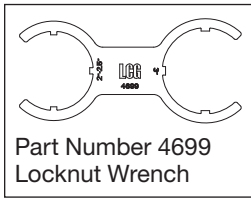

WARNING **CAUTION:** Always relieve pressure in the unit before attempting any repairs.

Material Code	
A	Buna-N
D	Viton ^{®a}

Ref No.	Part No.	Description	Qty.
1.	4667	Bypass valve cap	1
2.	4665	Bypass valve adjustment stem	1
3.	4659	Bypass valve cap gasket	1
4.	4613	Drilled - hex head bolt	4
5.	7012-006SF019E	Pan HD phillip 6-32 X3/16 in.-type F plated	4
6.	4626	Bypass valve tag	
7.	4675	Bypass valve cover	1
8.	4647	Spring guide	1
9.	4764	Spring (35–50 psi)—optional	1
	4765	Spring (50–75 psi)—optional	1
	4676	Spring (75–110 psi)—standard	1
	4766	Spring (110–125 psi)—optional	1
10.	4662	Shaft cover	1
11.	4697	Dirt shield	2
12.	4674	Bypass valve	1
13.	3442	Pipe plug - 1/4 in. NPT	2
14.	4767	Bypass valve cover gasket	1
15.	4670	Case	1
16.	4688	Flange gasket	2
17.	4673	Flange (2 in. NPT)—standard	2
	4666	Flange (2 in. weld)—optional	2
18.	7001-037NC125A	Hex head bolt	8

Ref No.	Part No.	Description	Qty.
19.	4695	Flange plug 2 in.	2
20.	4624	Nameplate	1
21.	4677	Vane	4
22.	4678	Vane driver	2
23.	4671-X2	Rotor shaft assembly—double	1
24.	4653	Shaft key	1
25.	2-258_ ^b	O-ring	2
26.	4640	Head	2
27.	7001-037NC100A	Hex head bolt	16
28.	4634-X_2 ^b	Seal assembly	2
29.	4648	Ball bearing	2
30.	4654	Shaft lockwasher	2
31.	4655	Shaft locknut	2
32.	4657	Bearing cap gasket	2
33.	4650	Grease seal	2
34.	1343	Grease relief fitting	2
35.	4649	Bearing cap	1
	4649-1	Blind bearing cap	1
36.	7001-037NC075A	Hex head bolt	8
37.	4651	Shaft protector	1
38.	2158	Grease zerk	2
39.	2159	Lubricap	2

^a Registered trademark of the DuPont company.

^b _ denotes material code.

Appendix E—Part Details for the PT25 with Standard Bypass Valve

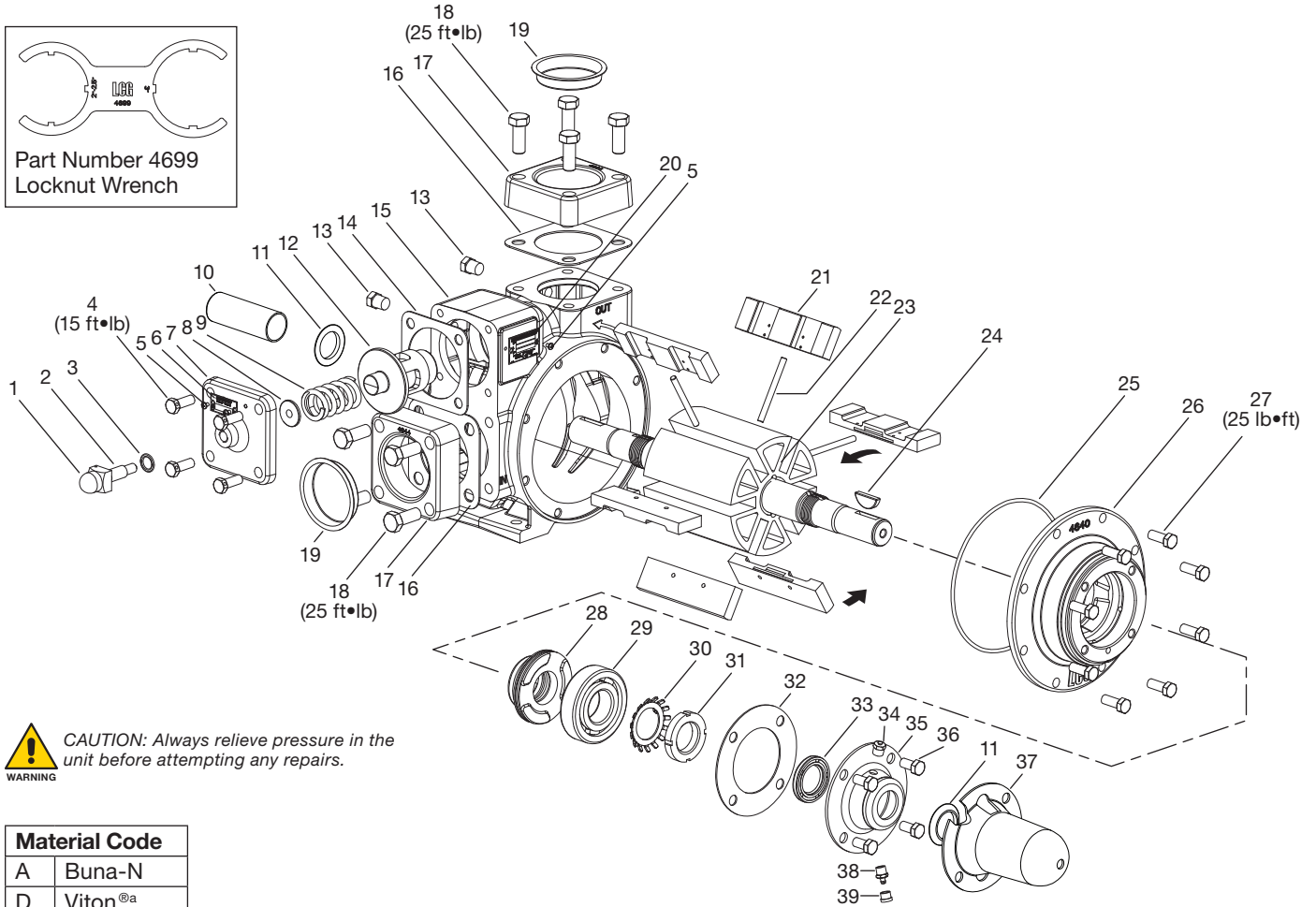
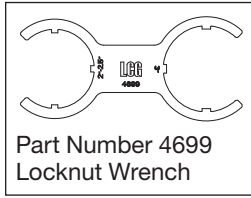

WARNING CAUTION: Always relieve pressure in the unit before attempting any repairs.

Material Code	
A	Buna-N
D	Viton ^{®a}

Ref No.	Part No.	Description	Qty.
1.	4667	Bypass valve cap	1
2.	4665	Bypass valve adjustment stem	1
3.	4659	Bypass valve cap gasket	1
4.	4613	Drilled - hex head bolt	4
5.	7012-006SF019E	Pan HD phillip 6-32 X3/16 in.- type F plated	4
6.	4626	Bypass valve tag	1
7.	4645	Bypass valve cover	1
8.	4647	Spring guide	1
9.	4646	Spring (50–110 psi)—standard	1
	4756	Spring (110–125 psi)—optional	1
10.	4662	Shaft cover	1
11.	4697	Dirt shield	2
12.	4643	Bypass valve	1
13.	3442	Pipe plug - 1/4 in.	2
14.	4660	Bypass valve cover gasket	1
15.	4639	Case	1
16.	4658	Flange gasket	2
	4644	Flange (2-1/2 in. NPT)—std.	2
17.	4568	Flange (2-1/2 in. weld)—opt.	2
	4698	Neck flange (2 in. NPT)—opt.	2
18.	7001-050NC175A	Hex head bolt	8
19.	4735	Flange plug	2

Ref No.	Part No.	Description	Qty.
20.	4624	Nameplate	1
21.	4696	Vane	6
22.	4652	Vane driver	3
23.	4641-X2	Rotor shaft assembly—double	1
24.	4653	Shaft key	1
25.	2-258 ^b	O-ring	2
26.	4640	Head	2
27.	7001-037NC100A	Hex head bolt	16
28.	4634-X ₂ ^b	Seal assembly	2
29.	4648	Ball bearing	2
30.	4654	Shaft lockwasher	2
31.	4655	Shaft locknut	2
32.	4657	Bearing cap gasket	2
33.	4650	Grease seal	2
34.	1343	Grease relief fitting	2
35.	4649	Bearing cap	1
	4649-1	Blind bearing cap	1
36.	7001-037NC075A	Hex head bolt	8
37.	4651	Shaft protector	1
38.	2158	Grease zerk	2
39.	2159	Lubricap	2

^a Registered trademark of the DuPont company.

^b _ denotes material code.

Appendix E—Part Details for the PT30 with Standard Bypass Valve

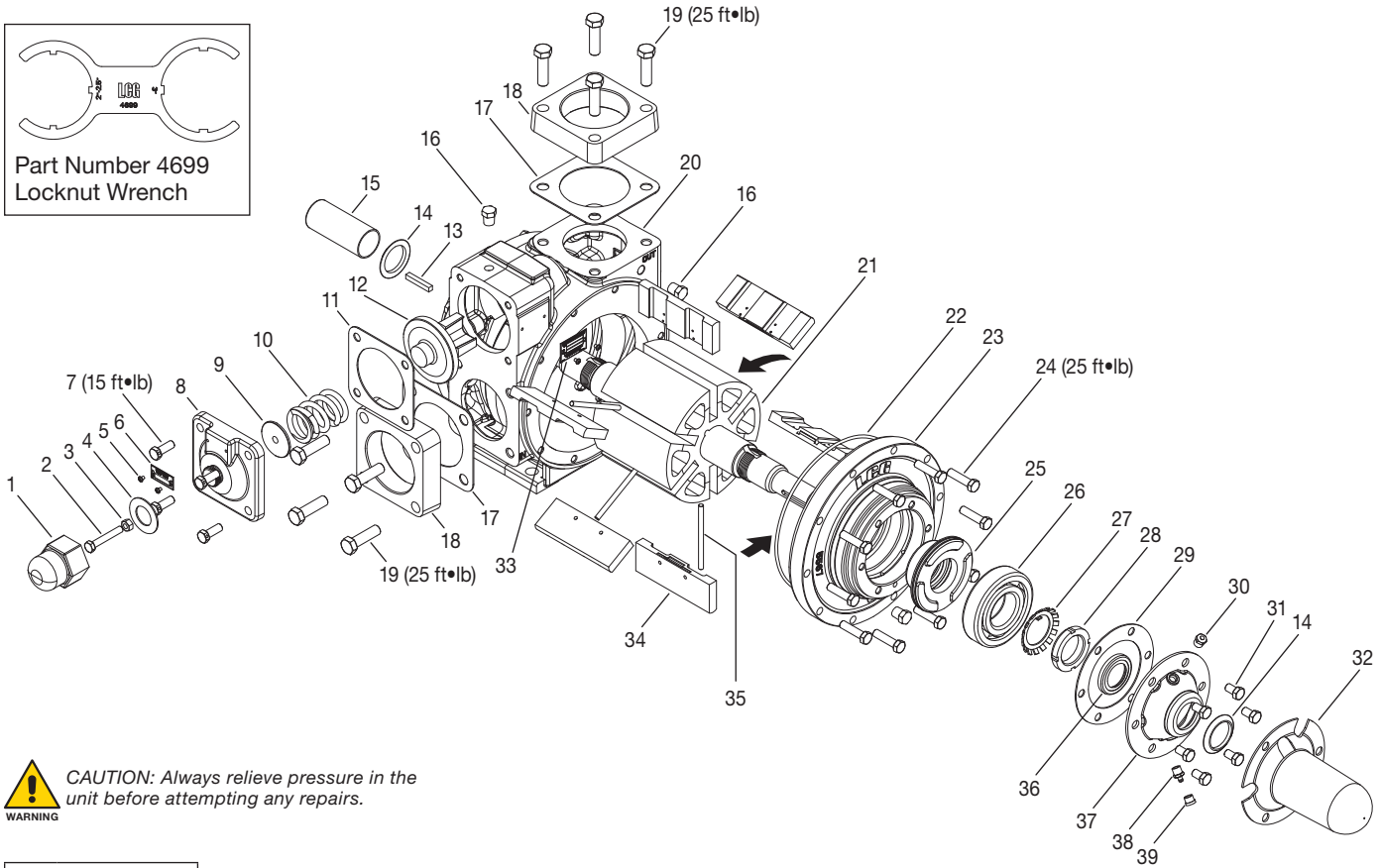
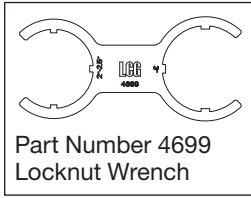

WARNING CAUTION: Always relieve pressure in the unit before attempting any repairs.

Material Code	
A	Buna-N
D	Viton ^{®a}

Ref No.	Part No.	Description	Qty.
1.	5457	Bypass valve cap	1
2.	5581	5/16-18 hex head bolt	1
3.	7101-031NC01A	Hex nut	1
4.	5597	Bypass/AOV cap gasket	1
5.	7012-006SF019E	Pan HD phillip 6-32 x 3/16" - type F plated	4
6.	4626	Bypass/AOV tag	1
7.	4613	Drilled hex head bolt	4
8.	5577	Bypass valve cover	1
9.	5580	Spring guide	1
10.	5579	Spring (50–110 psi)—standard	1
	4745	Spring (110–125 psi)—optional	1
11.	5578	Bypass/AOV cover gasket	1
12.	5575	Bypass valve	1
13.	2270	Shaft key	1
14.	4697-1	Dirt shield	2
15.	4609	Shaft cover	1
16.	3442	Pipe plug—1/4" NPT	4
17.	5596	Flange gasket	2
18.	5573	Flange (3 in. NPT)—standard	2
	5593	Flange (3 in. weld)—optional	2
19.	7001-050NC175A	Hex head bolt	8
20.	5565	Case	1

Ref No.	Part No.	Description	Qty.
21.	5569-X2	Rotor shaft assembly—double	1
22.	2-266_ ^b	O-ring	2
23.	4768	Head	2
24.	7001-037NC150A	Hex head bolt	20
25.	4621-X_2 ^b	Seal assembly	2
26.	5584	Ball bearing	2
27.	5591	Lockwasher	2
28.	5592	Locknut	2
29.	5595	Bearing cover gasket	2
30.	1343	Grease relief fitting	2
31.	7001-037NC075A	Hex head bolt	12
32.	5587	Shaft protector	1
33.	4624	Nameplate	1
34.	5588	Vanes	6
35.	5589	Vane driver	3
36.	5586	Grease seal	2
37.	5585	Bearing cap	1
	5585-1	Blind bearing cap	1
38.	2158	Grease zerk	2
39.	2159	Lubricap	2
40.	Consult factory	Flange plug—3 in.	2

^a Registered trademark of the DuPont company.

^b _ denotes material code.

Appendix E—Part Details for the PT/PTH20 Air Operated Valve (AOV)

5470-1XA Air Operated Valve (AOV) Assembly

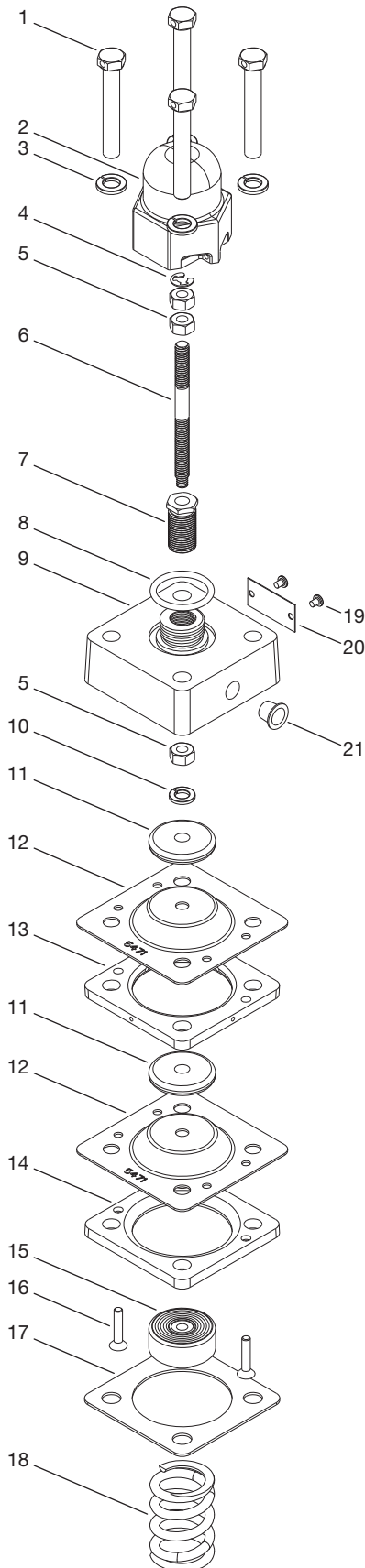

Ref No.	Part No.	Description	Qty.
1.	5500	Hex head bolt 3/8-16 x 2.50 SW	4
2.	5457	AOV cap	1
3.	7206-037A	Lockwasher	4
4.	5471-X	AOV adjustment stem retaining ring ¹	1
5.	5471-X	Hex nut ¹	3
6.	5471-X	AOV adjustment stem ¹	1
7.	5459	AOV low flow adjustment stem	1
8.	2-217A	O-ring	1
9.	5470	AOV housing	1
10.	5471-X	Lockwasher 0.3125 in. ¹	1
11.	5471-X	AOV disc ¹	2
12.	5471-X	AOV diaphragm ¹	2
13.	5464	AOV intermediate plate	1
14.	5465	AOV diaphragm cover plate	1
15.	5471-X	Diaphragm valve disc ¹	1
16.	5460	#10-24 x 1 flat head cap screw	2
17.	4767	AOV gasket	1
18.	4755	Spring	1
19.	7012-006SF019E	Pan HD phillip 6-32 x3/16"-type f plated	2
20.	4626	Bypass/AOV tag	1
21.	2854	Pipe plug	1

¹ Not sold separately. Only available with 5471-X air operated valve (AOV) diaphragm assembly.

Appendix E—Part Details for the PT/PTH25 Air Operated Valve (AOV)

5462-1XA Air Operated Valve (AOV) Assembly

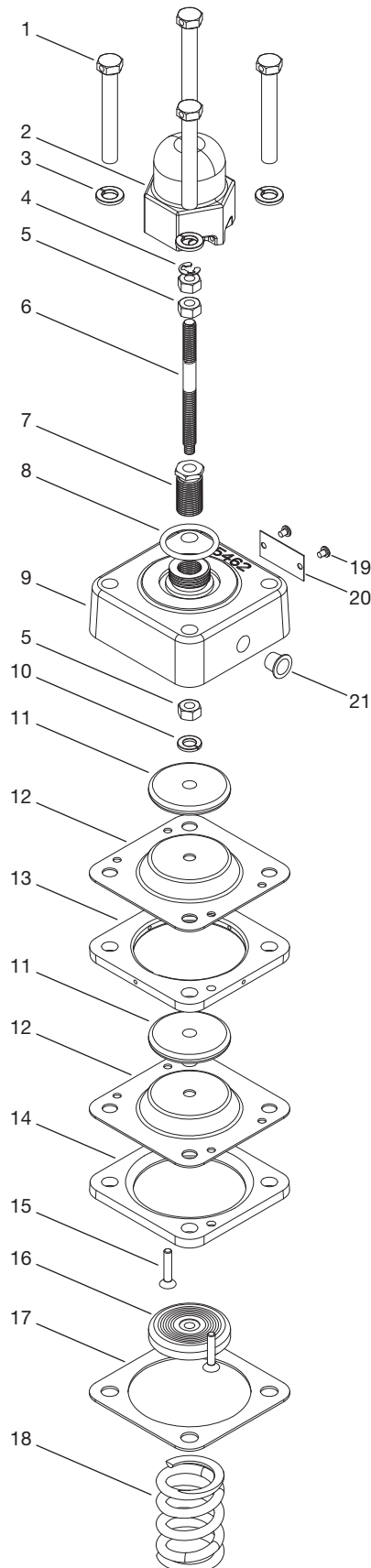

Ref No.	Part No.	Description	Qty.
1.	5501	Hex head bolt 3/8-16 x 2.75 SW	4
2.	5457	AOV cap	1
3.	7206-037A	Lockwasher	4
4.	5466-X	AOV adjustment stem retaining ring ¹	1
5.	5466-X	Hex nut ¹	3
6.	5466-X	AOV adjustment stem ¹	1
7.	5459	AOV low flow adjustment stem	1
8.	2-217A	O-ring	1
9.	5462	AOV housing	1
10.	5466-X	Lockwasher 0.3125 in. ¹	1
11.	5466-X	AOV disc ¹	2
12.	5466-X	AOV diaphragm ¹	2
13.	5461	AOV intermediate plate	1
14.	5463	AOV diaphragm cover plate	1
15.	5460	#10-24 x 1 flat head cap screw	2
16.	5466-X	Diaphragm valve disc ¹	1
17.	4660	AOV gasket	1
18.	4757	Spring	1
19.	7012-006SF019E	Pan HD phillip 6-32 x3/16"-type F plated	2
20.	4626	Bypass/AOV tag	1
21.	2854	Pipe plug	1

¹ Not sold separately. Only available with 5466-X air operated valve (AOV) diaphragm assembly.

Appendix E—Part Details for the PT/PTH30 Air Operated Valve (AOV)

5566-XA Air Operated Valve (AOV) Assembly

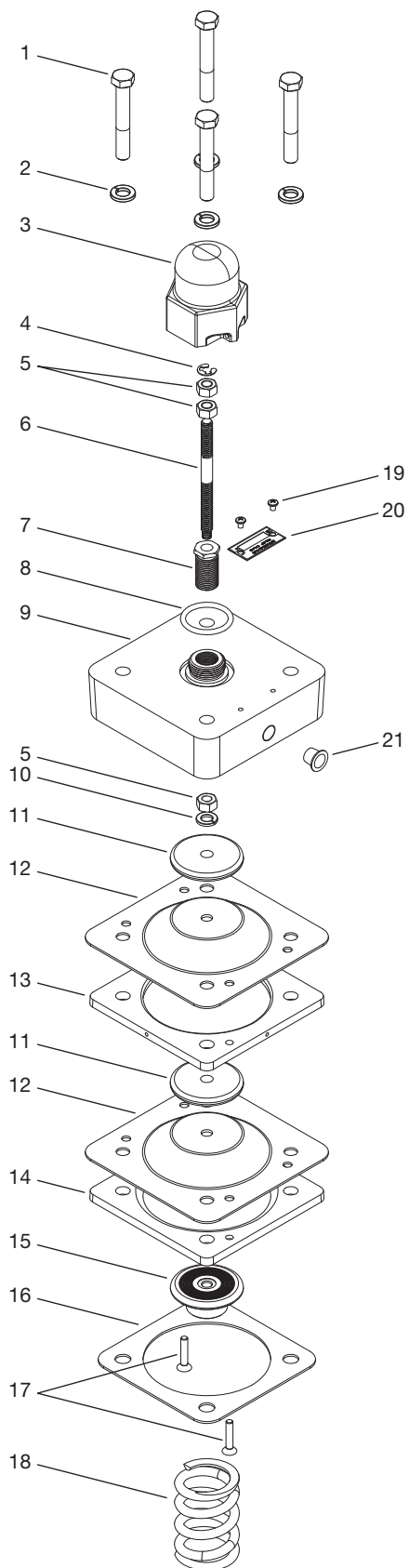

Ref No.	Part No.	Description	Qty.
1.	5501	Hex head bolt 3/8-16x2.75 SW	4
2.	7206-037A	Lockwasher	4
3.	5457	AOV cap	1
4.	5570-X	AOV adjustment stem retaining ring ¹	1
5.	5570-X	Hex nut (locknut) ¹	3
6.	5570-X	AOV adjustment stem ¹	1
7.	5459	AOV low pressure adjustment stem	1
8.	2-217A	O-ring	1
9.	5566	AOV housing	1
10.	5570-X	Lockwasher 0.3125 in. ¹	1
11.	5570-X	AOV disc ¹	2
12.	5570-X	AOV diaphragm ¹	2
13.	5568	AOV intermediate plate	1
14.	5576	AOV diaphragm cover plate	1
15.	5570-X	Diaphragm valve disc ¹	1
16.	5578	AOV gasket	1
17.	5460	#10-24 x 1 flat head cap screw	2
18.	5579	Spring	1
19.	7012-006SF019E	Pan HD phillip 6-32 x 3/16 in. type F plated	2
20.	4626	Bypass/AOV tag	1
21.	2854	Pipe plug	1

¹ Not sold separately. Only available with 5570-X air operated valve (AOV) diaphragm assembly.

Appendix E—Part Details for PT/PTH20 Strainer

4684-X Strainer Assembly

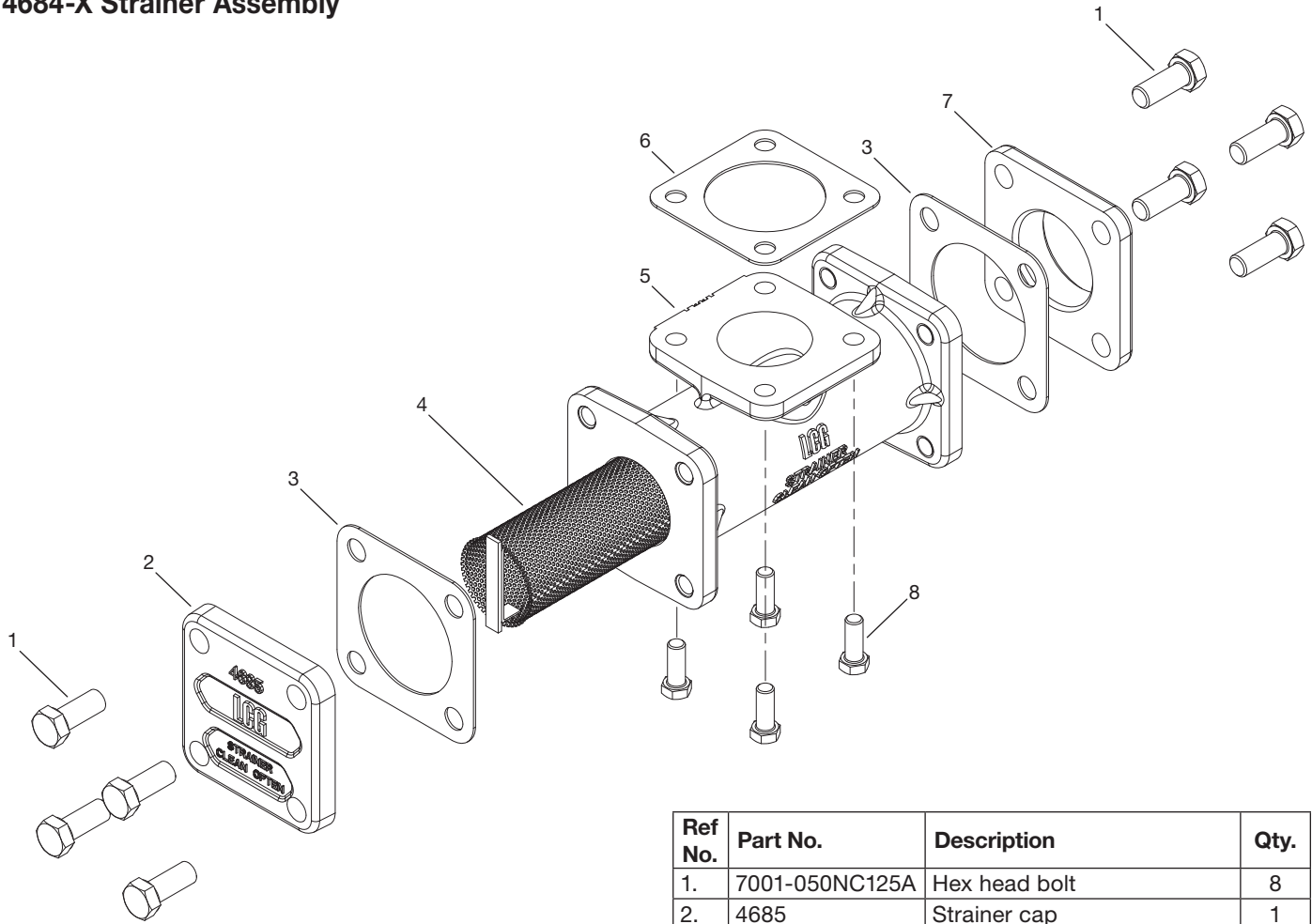

Ref No.	Part No.	Description	Qty.
1.	7001-050NC125A	Hex head bolt	8
2.	4685	Strainer cap	1
3.	4658	Flange gasket	2
4.	4686	Strainer basket	1
5.	4684	Strainer body	1
6.	4688	Flange gasket	1
7.	4698	2 in. NPT flange	1
8.	7001-037NC100A	Hex head bolt	4

Appendix E—Part Details for PT/PTH25 Strainer

4689-X Strainer Assembly

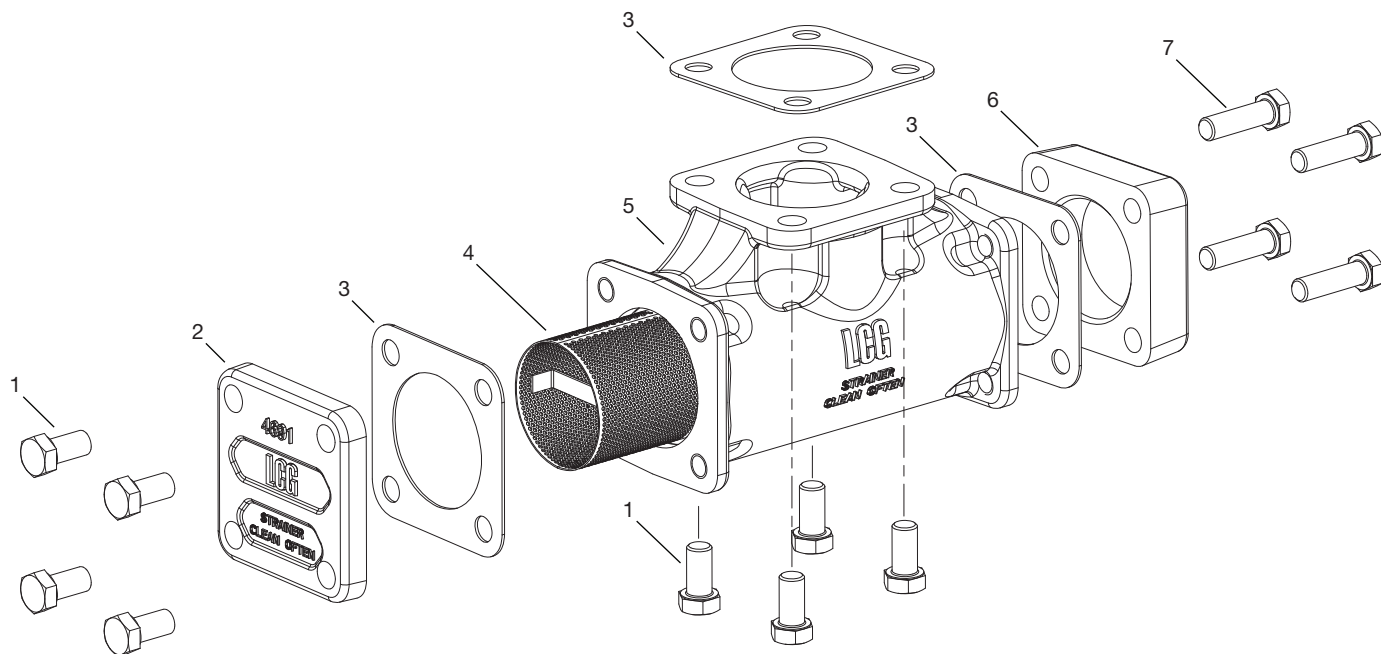

Ref No.	Part No.	Description	Qty.
1.	7001-050NC100A	Hex head bolt	8
2.	4691	Strainer cap	1
3.	4658	Flange gasket	3
4.	4690	Strainer basket	1
5.	4689	Strainer body	1
6.	4644	2.5 in. NPT flange	1
7.	7001-050NC175A	Hex head bolt	4

Appendix E—Part Details for PT/PTH30 Strainer

4680-X Strainer Assembly

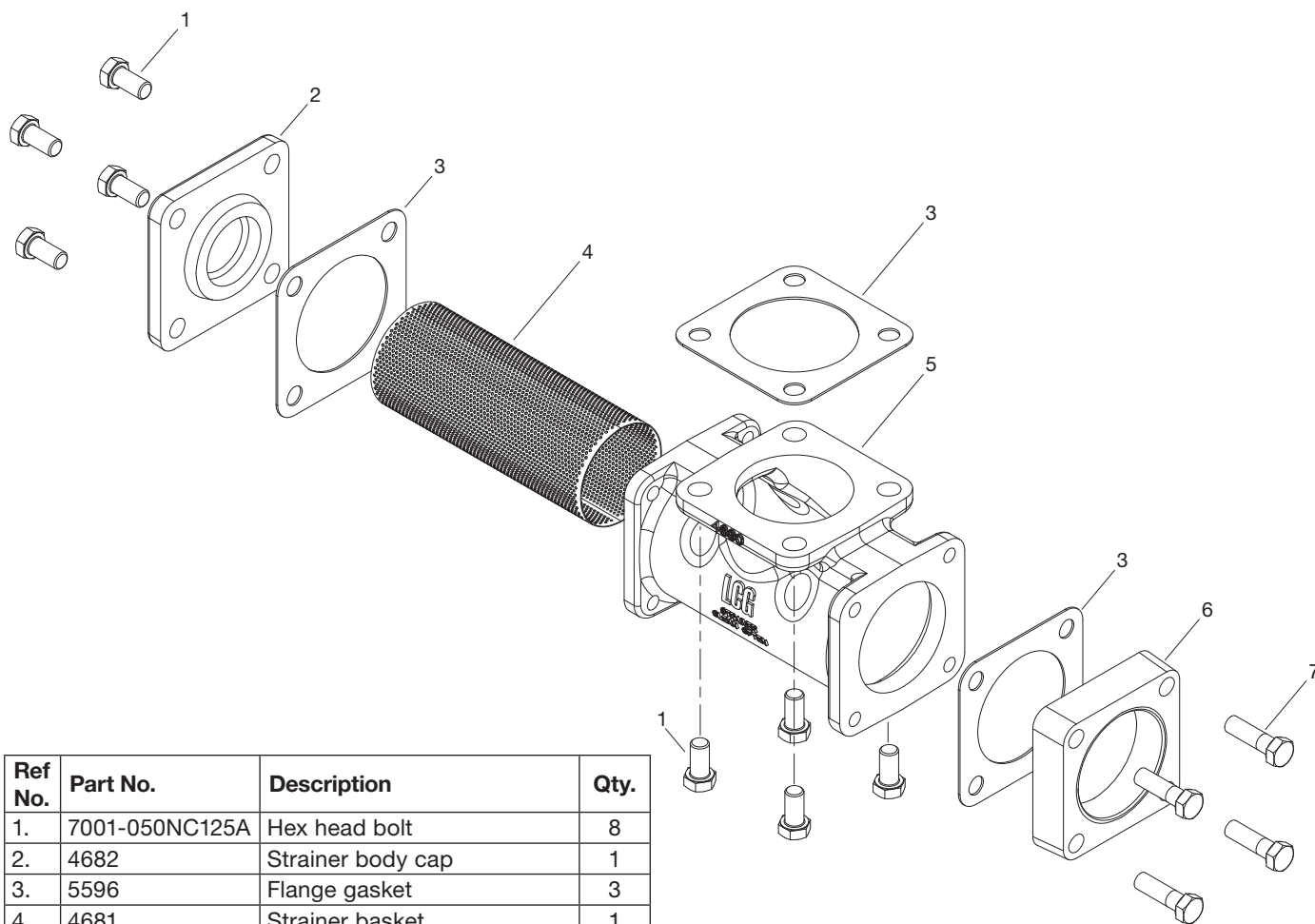

Ref No.	Part No.	Description	Qty.
1.	7001-050NC125A	Hex head bolt	8
2.	4682	Strainer body cap	1
3.	5596	Flange gasket	3
4.	4681	Strainer basket	1
5.	4680	Strainer body	1
6.	5573	3 in. NPT flange	1
7.	7001-050NC175A	Hex head bolt	4

Appendix E—Part Details for the PT-Series and Hydraulic Drive Adapter

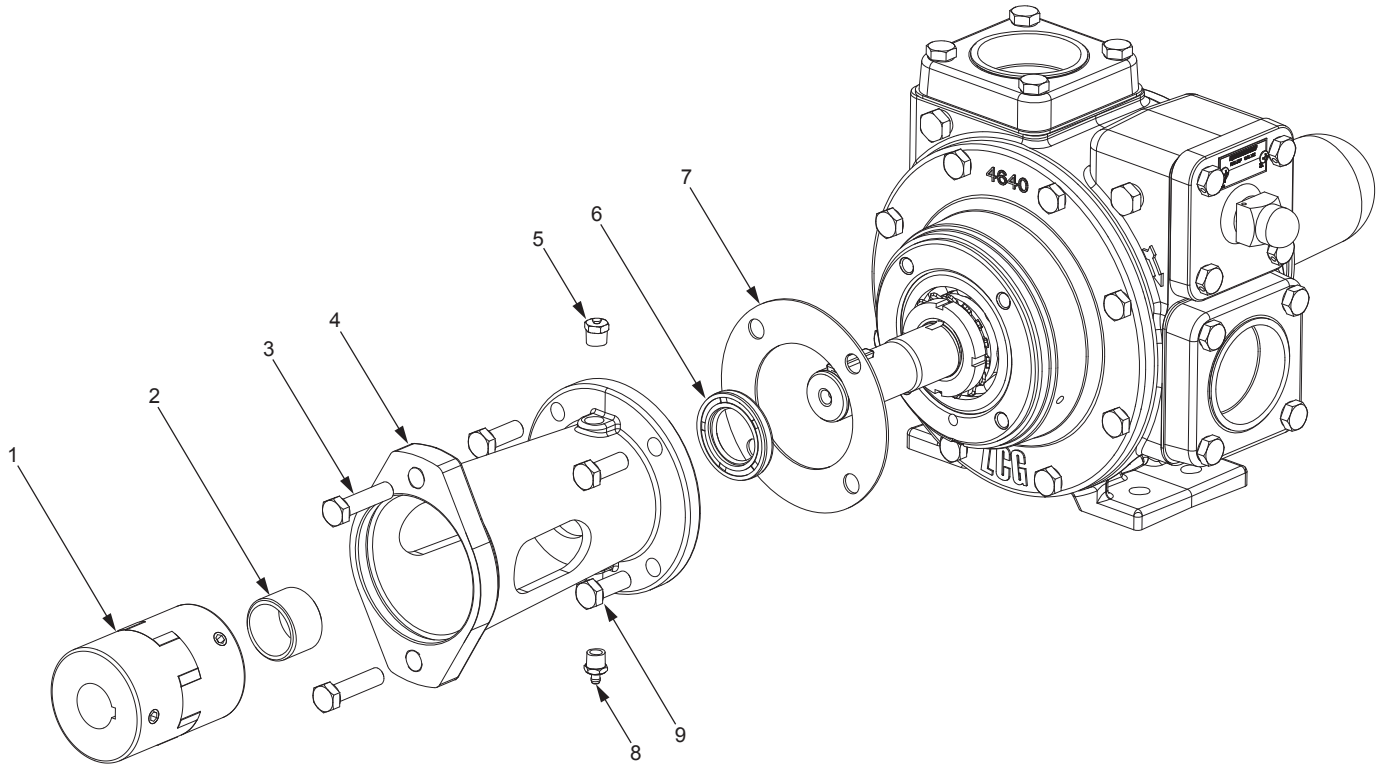

PTH20 and PTH25 Hydraulic Drive Assembly 4899-X1 (1-1/8" x 1" Bore Size)

Ref No.	Part No.	Description	Qty.
1	1380-1	CJ 28/38 coupling (1-1/8" x 1")	1
2	4897	Hydraulic lockring	1
3	7301-120MC040A	M12 x 1.75 x 40 metric hex head bolt	2
4	4899	Hydraulic adapter	1
5	1343	Grease relief fitting	1
6	4650	Grease seal	1
7	4657	Bearing cap gasket	1
8	2158	Grease zerk	1
9	7001-037NC100A	3/8-16 x 1 hex head bolt	4

PTH30 Hydraulic Drive Assembly 4898-X1 (1-1/8" x 1" Bore Size)

Ref No.	Part No.	Description	Qty.
1	1380-1	CJ 28/38 coupling (1-1/8" x 1")	1
2	4897	Hydraulic lockring	1
3	7301-120MC040A	M12 x 1.75 x 40 metric hex head bolt	2
4	4898	Hydraulic adapter	1
5	1343	Grease relief fitting	1
6	4896	Grease seal	1
7	5595	Bearing cap gasket	1
8	2158	Grease zerk	1
9	7001-037NC100A	3/8-16 x 1 hex head bolt	6

4899-X2 (1-1/8" x 1-1/4" Bore Size)

Ref No.	Part No.	Description	Qty.
1	1380-2	CJ 28/38 coupling (1-1/8" x 1-1/4")	1
2	4897	Hydraulic lockring	1
3	7301-120MC040A	M12 x 1.75 x 40 metric hex head bolt	2
4	4899	Hydraulic adapter	1
5	1343	Grease relief fitting	1
6	4650	Grease seal	1
7	4657	Bearing cap gasket	1
8	2158	Grease zerk	1
9	7001-037NC100A	3/8-16 x 1 hex head bolt	4

4898-X2 (1-1/8" x 1-1/4" Bore Size)

Ref No.	Part No.	Description	Qty.
1	1380-2	CJ 28/38 coupling (1-1/8" x 1-1/4")	1
2	4897	Hydraulic lockring	1
3	7301-120MC040A	M12 x 1.75 x 40 metric hex head bolt	2
4	4898	Hydraulic adapter	1
5	1343	Grease relief fitting	1
6	4896	Grease seal	1
7	5595	Bearing cap gasket	1
8	2158	Grease zerk	1
9	7001-037NC100A	3/8-16 x 1 hex head bolt	6

Appendix F—Troubleshooting Guide

In diagnosing pump and system troubles, record the following data during product transfers:

1. Pressure at pump suction.
2. Pressure at pump discharge.
3. Pipe size and length of suction and discharge lines.
4. Pump speed if practical.

Symptom	Probable Cause	Remedy
Low capacity	Pump speed too slow	Check engine speed and PTO ratio. Consult pump performance curve. Use tachometer on pump if speed is questionable.
	High differential pressure	Restriction in discharge piping or hose too small. Pump speed too high.
	Clogged strainer	Clean strainer.
	Suction pipe too small or restricted	Indicated by pump inlet pressure dropping several pounds when pump is restarted. Remove restriction or modify piping.
	Worn vanes	Replace.
	Worn sideplates	Reverse or replace sideplates. Check universal drive assembly to make sure angularity is within limits, yokes are parallel and slip-joint is greased. Check bearings.
	Vanes sticking	Remove vanes and clean out foreign material (check strainer). Replace vanes if swollen.
Pump runs but no flow	Valve closed	Check valves. Make sure tank valve is open! Refer to manufacturer's instructions.
	Broken shaft	Disassemble and inspect pump. Repair if necessary.
	Defective meter	Service meter.
Pump will not turn— locked up	Foreign matter in pump	Clean out the pump—check strainer in suction line.
	Vanes broken	Clean out pump carefully and replace vanes. Has pump been operated dry? Then, check for damage to cam and rotor shaft assembly.
	Bearing seized	Replace pump bearings. Grease monthly. Use ball bearing grease manufactured for intended service.
	Moisture frozen in pump	Let thaw and break loose carefully.
Will not build pressure	Poor suction conditions	Clean inlet strainer. Increase pipe size.
	Internal bypass valve set too low or stuck open	Check valve or set valve for higher pressure (see instructions).
	Worn vanes and/or sideplates	Disassemble, inspect and repair as necessary. Has pump been run dry? If so check for damage to vanes & rotor-shaft assembly.
Pump is noisy	Cavitation from poor suction conditions	Clean inlet strainer. Increase pipe size.
	Vanes sticking	Remove vanes and clean out foreign material (check strainer). Replace vanes if swollen.
	Bearings worn	Replace if necessary—grease monthly.
	Very high differential pressure	Check for restriction in discharge line. Delivery hose too small and too long? Slow down pump!
		Check vapor release float assembly on meter air eliminator and meter differential valve.
PTO shaft vibration	Inspect and repair driveline component.	
Pump leaks around shaft	Seal or O-rings failed	Inspect seal assembly and replace if necessary. Keep new seal very clean when replacing seal. Recommend a light oil film on O-rings. Has pump been run dry? If so check for damage to vanes & rotor-shaft assembly.

Appendix G—Flush and Storage Instructions

If the pump is removed from service for some time, it must be protected. Piping and tanks not in service should also be protected, as the rust particles can destroy the pump's seals almost immediately after start-up.

1. Fill or thoroughly flush the pump with a light rust inhibiting oil. If the pump is flushed with oil, place some desiccant packets inside the pump for added protection.
2. Plug all pump openings.
3. Store in a dry location.
4. Before placing the pump back into service, drain the oil and remove any desiccant packets.
5. Refer to the "Operation" section and follow each step.

Solutions beyond products...

CORKEN[®]

CORKEN, INC. • A Unit of IDEX Corporation

9201 North I-35 Service Road, Oklahoma City, OK. 73131

Phone (405) 946-5576 • Fax (405) 948-7343

Website: www.corken.com

E-mail: cocsalesdept@idexcorp.com



[@CorkenInc](https://twitter.com/CorkenInc)

