

SELF PRIMING ENGINE DRIVEN PUMPS

RB316

ROBUSTA
Hydraulic System

VIESSE
POMPE • ITALIA



The self priming pumps "Robusta", are designed to comply to the hardest and heavy duty applications, such as: building, emergency and industrial sectors.

The open-blade double-curvature impeller, unique across the world, ensures a superior priming ability voiding the need of a foot valve installation. The high thickness of the pump body and of the impeller blades, allow the handling of more abrasive fluids and large passage of solids.

FEATURES

- ✓ EN-JL1030 cast iron construction according to UNI EN 1561 with modular body.
- ✓ Replaceable screw-less armoured internal volute in EN-JS1030 nodular cast iron according to UNI EN 1563.
- ✓ Mechanical seal in high resistance hard metal.
- ✓ Large-size inspection hatches to facilitate cleaning and inspection.
- ✓ Standardised EN1092-1:2003 flanged inlet and outlet with built in threaded rod.
- ✓ Rapid self-priming up to 8 meters in vertical position.

VERSIONS

Code	RB316BGLD35+T	RB316AGLD44+T
PUMP		
RPM	3000	3200
P MAX pump (kW)	4.5	6.5
Q MAX (m ³ /h)	100	100
H MAX (m)	23	30
Ø Inlet/outlet DN (mm - ")	80 (3")	80 (3")
Ø Impeller (mm)	138	146
Free solids passage MAX size (mm)	35 x 25	35 x 25

ENGINE DRIVEN

	Lombardini 15LD350	Lombardini 15LD440
Brand	Lombardini 15LD350	Lombardini 15LD440
N. cylinders	1	1
Displacement (cc)	349	442
Motor power - MAX (kW)	5.5	8.1
Cooling	Air	Air
Fuel	Diesel	Diesel
Starting system	Recoil *	Recoil *

PUMP SET UP AVAILABLE

	Direct / Monobloc	Direct / Monobloc
Coupling versions	Direct / Monobloc	Direct / Monobloc
Tank capacity (L)	4.3	5.0
Total weight version +T (kg) **	130	125
Base frame (+B)	✓	✓
Trailer (+T) simple version manually-driven	✓	✓

STANDARD MATERIAL OF CONSTRUCTION

Pump body	Cast Iron GJL250
Armoured volute	Nodular cast iron GJS400
Open-blade impeller	Nodular cast iron GJS400
Mechanical Seal	Silicon Carbide / Viton®
Shaft	Steel C40
Elastomers	Nitrile

Special metallurgies available on demand.

OPTIONAL ACCESSORIES

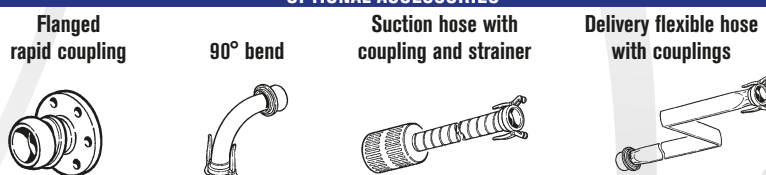

* Version with electric start available on trolley (+TE) - Version with electric start available on base frame (+BE)
** Empty tank.

SELF PRIMING ENGINE DRIVEN PUMPS

RB316

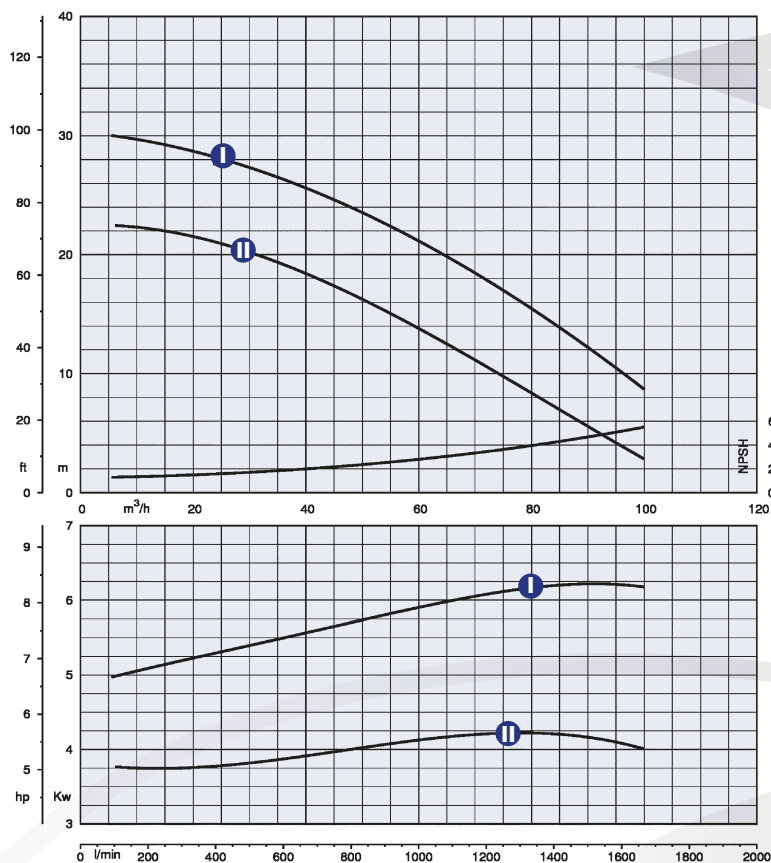

RB 316 revision: 17-06-20

PUMP PERFORMANCE RANGE

I **RB316AGLD44+T**

II **RB316BGLD35+T**

Performances are subjected to variations based on NPSH available.

DIMENSIONS mm

	A	A1	B	C
Version +T	860	830	590	1000

All dimensions and data a.m. reported are indicative, not binding and subjected to modifications without notice.

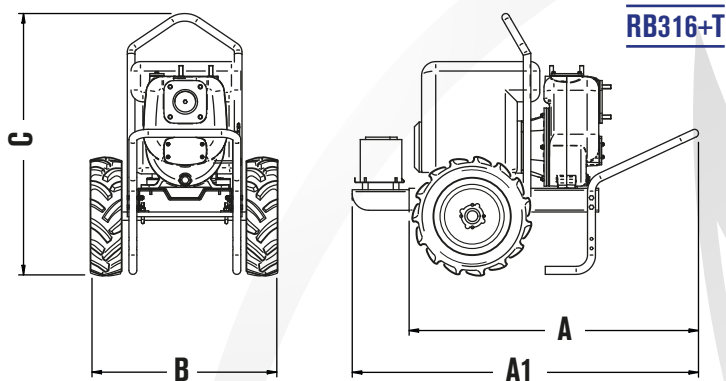

RB316+T

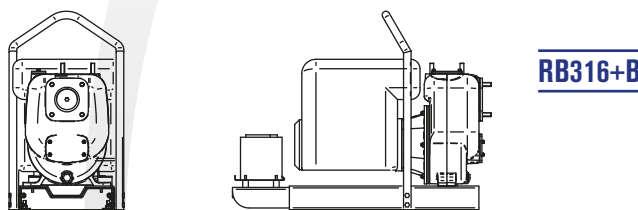

RB316+B